



Operating Instructions and Parts Manual 12" Variable Speed Drill Press

Model: JWDP-12



JET
427 New Sanford Road
LaVergne, Tennessee 37086
Ph.: 800-274-6848
www.jettools.com

Part No. M-716000
Edition 1 12/2015
Copyright © 2015 JET



1.0 IMPORTANT SAFETY INSTRUCTIONS

WARNING – To reduce risk of injury:

1. Read and understand the entire owner's manual before attempting assembly or operation.
2. Read and understand the warnings posted on the machine and in this manual. Failure to comply with all of these warnings may cause serious injury.
3. Replace the warning labels if they become obscured or removed.
4. This drill press is designed and intended for use by properly trained and experienced personnel only. If you are not familiar with the proper and safe operation of a drill press, do not use until proper training and knowledge have been obtained.
5. Do not use this drill press for other than its intended use. If used for other purposes, JET disclaims any real or implied warranty and holds itself harmless from any injury that may result from that use.
6. Always wear ANSI Z87.1 approved safety glasses or face shield while using this drill press. (Everyday eyeglasses only have impact resistant lenses; they are *not* safety glasses.)
7. Before operating this machine, remove tie, rings, watches and other jewelry, and roll sleeves up past the elbows. Do not wear loose clothing. Confine long hair. Non-slip footwear or anti-skid floor strips are recommended. Do not wear gloves.
8. Wear ear protectors (plugs or muffs) during extended periods of operation.
9. Some dust created by power sanding, sawing, grinding, drilling and other construction activities contain chemicals known to cause cancer, birth defects or other reproductive harm. Some examples of these chemicals are:
 10. Lead from lead based paint.
 11. Crystalline silica from bricks, cement and other masonry products.
 12. Arsenic and chromium from chemically treated lumber.
13. Your risk of exposure varies, depending on how often you do this type of work. To reduce your exposure to these chemicals, work in a well-ventilated area and work with approved safety equipment, such as face or dust masks that are specifically designed to filter out microscopic particles.
14. Do not operate this machine while tired or under the influence of drugs, alcohol or any medication.
15. Make certain the switch is in the **OFF** position before connecting the machine to the power supply.
16. Make certain the machine is properly grounded.
17. Make all machine adjustments or maintenance with the machine unplugged from the power source.
18. Remove adjusting keys and wrenches. Form a habit of checking to see that keys and adjusting wrenches are removed from the machine before turning it on.
19. Keep safety guards in place at all times when the machine is in use. If removed for maintenance purposes, use extreme caution and replace the guards immediately.
20. Make sure the drill press is firmly secured to the floor or bench before use.
21. Check damaged parts. Before further use of the machine, a guard or other part that is damaged should be carefully checked to determine that it will operate properly and perform its intended function. Check for alignment of moving parts, binding of moving parts, breakage of parts, mounting and any other conditions that may affect its operation. A guard or other part that is damaged should be properly repaired or replaced.
22. Provide for adequate space surrounding work area and non-glare, overhead lighting.
23. Keep the floor around the machine clean and free of scrap material, oil and grease.
24. Don't use in dangerous environment. Don't use power tools in damp or wet locations, or expose them to rain. Keep work area well lighted.
25. Keep visitors a safe distance from the work area. **Keep children away.**
26. Make your workshop child proof with padlocks, master switches or by removing starter keys.
27. Give your work undivided attention. Looking around, carrying on a conversation and "horse-play" are careless acts that can result in serious injury.
28. Maintain a balanced stance at all times so that you do not fall or lean against the spindle or other moving parts. Do not overreach or use excessive force to perform any machine operation.
29. Use the right tool at the correct speed and feed rate. Do not force a tool or attachment to do a job for which it was not designed. The right tool will do the job better and more safely.
30. Use recommended accessories; improper accessories may be hazardous.

31. Maintain tools with care. Keep drill bits sharp and clean for the best and safest performance. Follow instructions for lubricating and changing accessories.
32. Disconnect tools before servicing; when changing accessories, such as blades, bits, cutters and the like.
33. Make sure the work piece is securely attached or clamped to the table. Never use your hand to hold the work piece.
34. Turn off the machine before cleaning. Use a brush or compressed air to remove chips or debris — do not use your hands.
35. Do not stand on the machine. Serious injury could occur if the machine tips over.
36. Never leave the machine running unattended. Turn the power off and do not leave the machine until it comes to a complete stop.
37. Remove loose items and unnecessary work pieces from the area before starting the machine.

Familiarize yourself with the following safety notices used in this manual:

CAUTION This means that if precautions are not heeded, it may result in minor injury and/or possible machine damage.

WARNING This means that if precautions are not heeded, it may result in serious injury or possibly even death.

SAVE THESE INSTRUCTIONS

2.0 About this manual

This manual is provided by JET covering the safe operation and maintenance procedures for a JET JWDP-12 Drill Press. This manual contains instructions on installation, safety precautions, general operating procedures, maintenance instructions and parts breakdown. Your machine has been designed and constructed to provide consistent, long-term operation if used in accordance with the instructions set forth in this document.

If there are questions or comments, please contact your local supplier or JET. JET can also be reached at our web site: www.jettools.com.

Retain this manual for future reference. If the machine transfers ownership, the manual should accompany it.

WARNING Read and understand the entire contents of this manual before attempting assembly or operation! Failure to comply may cause serious injury

3.0 Table of contents

- 1.0 IMPORTANT SAFETY INSTRUCTIONS 2
- 2.0 About this manual 3
- 3.0 Table of contents 4
- 4.0 Specifications..... 5
- 5.0 Unpacking..... 6
 - 5.1 Contents of shipping container..... 6
- 6.0 Assembly..... 7
 - 6.1 Base and column assembly 7
 - 6.2 Table and rack..... 7
 - 6.3 Table height adjust and lock handles 7
 - 6.4 Mounting the head..... 8
 - 6.5 Installing handles..... 8
 - 6.6 Installing chuck and arbor 8
 - 6.7 Mounting to bench 8
- 7.0 Electrical connections 9
 - 7.1 GROUNDING INSTRUCTIONS..... 9
 - 7.2 Extension cords..... 9
- 8.0 Adjustments..... 10
 - 8.1 Removing chuck and arbor 10
 - 8.2 Adjusting depth stop 10
 - 8.3 Spindle speed adjust 10
 - 8.4 Return spring adjustment..... 11
 - 8.5 Laser adjustment..... 11
- 9.0 Features and controls 12
- 10.0 Lubrication 12
- 11.0 Basic operation 12
- 12.0 Troubleshooting JWDP-12 Drill Press..... 13
- 13.0 Replacement parts 14
 - 13.1.1 JWDP-12 Drill Press – Exploded View 14
 - 13.1.2 JWDP-12 Drill Press – Parts List..... 15
- 14.0 Electrical connections – JWDP-12..... 18
- 15.0 Warranty and Service..... 19

4.0 Specifications

Model Number	JWDP-12
Stock Number	716000
Swing	12 in. (305mm)
Type	Bench Top
Drilling Capacity	5/8 in. (16mm)
Chuck Size	5/8 in. (0.8-16mm)
Spindle Travel	3-1/8 in. (80mm)
Spindle Distance to Base	23-3/8 in. (593mm)
Spindle Distance to Table (max.)	17 in. (431.8mm)
Table Size Diameter (width x depth)	9-1/2 x 9-1/2 in. (243x243mm)
Table Tilt	+ or - 45°
Spindle Taper	MT2
Column Diameter	2-1/2 in. (65mm)
Number of Spindle Speeds	Variable
Range of Spindle Speeds	530-3100 RPM
Light Bulb	40W max.
Overall Height	37 in. (940mm)
Base Size	10 x 16-1/8 in. (252x410mm)
Motor	115V only, 1/3HP, 1 PH, 5.0A, 60Hz
Net Weight (approx.)	85 lb. (38 kg)
Shipping Weight (approx.)	92.5 lb. (42 kg)

The specifications in this manual are given as general information and are not binding. JET reserves the right to effect, at any time and without prior notice, changes or alterations to parts, fittings, and accessory equipment deemed necessary for any reason whatsoever.

⚠WARNING Read and understand the entire contents of this manual before attempting assembly or operation! Failure to comply may cause serious injury!

5.0 Unpacking

⚠WARNING Read and understand all assembly instructions before attempting assembly. Failure to comply may cause serious injury.

Separate all parts from the packing material. Check each part against sect. 5.1, *Contents of shipping container* and make certain that all items are accounted for before discarding any packing material.

5.1 Contents of shipping container

Refer to Figures 1 and 2.

- 1 Head Assembly – A
- 1 Table – B
- 1 Table Arm & Support Assembly – C
- 1 Base – D
- 1 Column and Rack Assembly – E
- 4 Handles – F
- 1 Arbor – G
- 1 Drift Key – H
- 1 Chuck Key – J
- 2 Lock Handles – K
- 1 Owner's Manual
- 1 Warranty Registration Card

Hardware

- 4 M10 x 25 Hex Cap Screws – N
- 1 Chuck – O
- 2 Table Extension Lock Knobs – P
- 1 Table Height Adjust Handle – Q

Tools supplied for assembly

- 1 3mm Hex Wrench – L
- 1 4mm Hex Wrench – M

Additional tools required: 5/8" Wrench

Before Assembly

1. Remove contents from shipping container.
2. Compare contents of shipping container with the list found above. Report any shortages or damage to your JET distributor.
3. Clean all rust protected surfaces with kerosene or a light solvent. Do not use lacquer thinner, paint thinner, or gasoline. These will damage plastic components and painted surfaces.

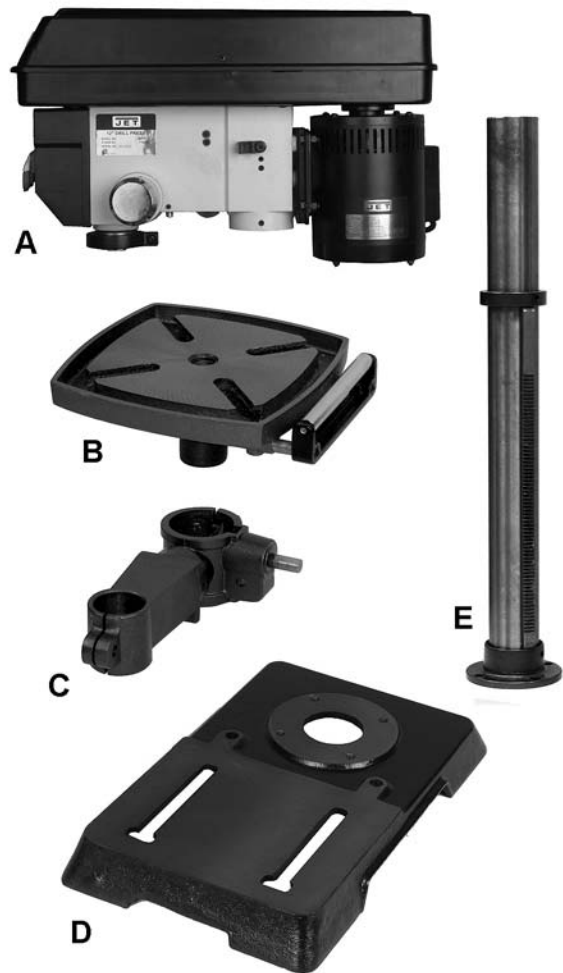

Figure 1: contents of shipping container

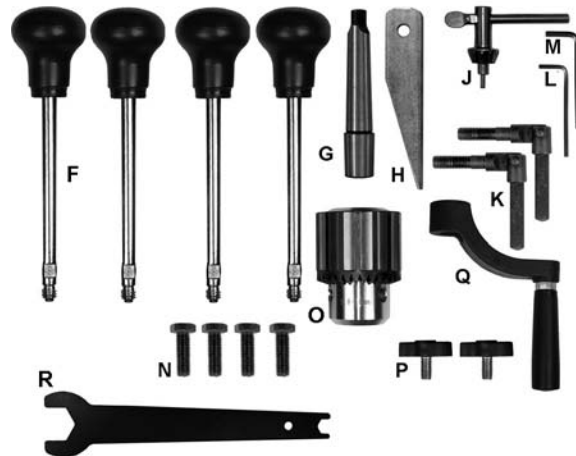

Figure 2: Additional contents

6.0 Assembly

6.1 Base and column assembly

Refer to Figure 3:

1. Place *base* (D) on a level floor.
2. Place *column assembly* (E) on *base* (D) and align holes in column support with holes in base.
3. Using a 5/8-in wrench, secure *column* (E) with four M10 x 25 *hex cap screws* (N) to the base.

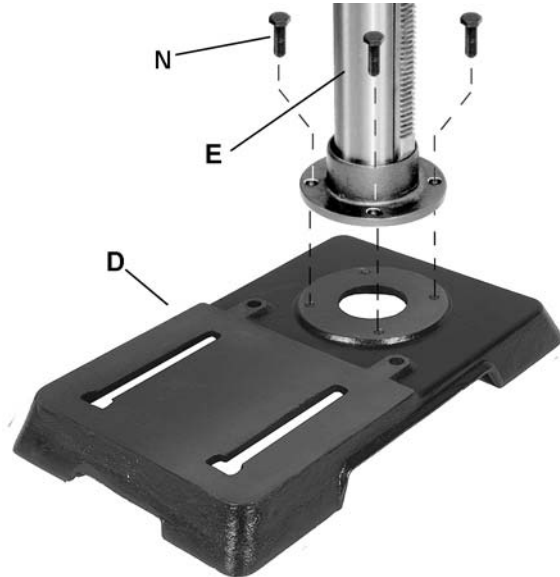

Figure 3

6.2 Table and rack

Refer to Figure 4:

Note: If table arm/support assembly (C) and rack (E₃) are already installed on column (E), proceed to step 4. Otherwise, begin with step 1.

1. Remove *rack ring* (E₁) and *rack* (E₃) from *column* (E). Note which end of the rack is up. It must be reinstalled later with the same side up.
2. Place *rack* (E₃) inside *table support* (C) such that the teeth of the *rack* (E₃) mesh with the pinion gear on the end of the table crank handle *shaft* (C₁).
3. Slide table arm/support assembly (C) together with the *rack* (E₃) onto the *column* (E) as shown.
4. Place *rack ring* (E₁) onto *column* (E), sliding it down so it rests against *rack* (E₃) as shown, and tighten *setscrew* (E₂) with a 3mm hex wrench (provided).
5. Place *table* (B) onto *table arm* (C), positioning it as shown in Figure 4. Secure table with *lock handle* (K).
6. Secure table extension (B₁) with two *table extension lock knobs* (Q).

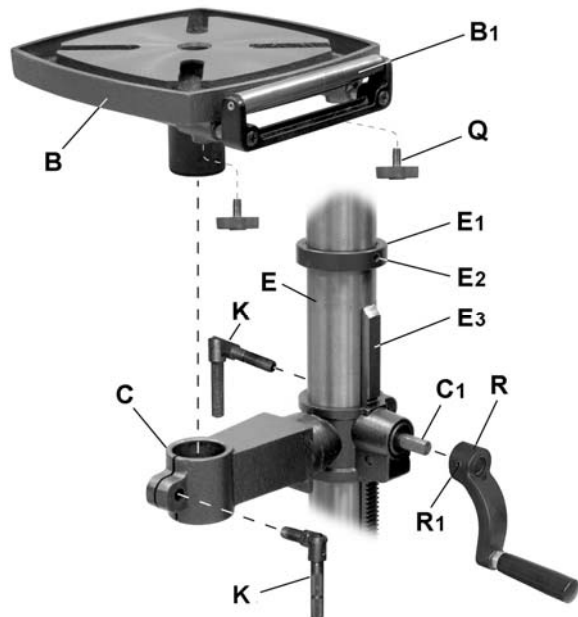

Figure 4

6.3 Table height adjust and lock handles

Refer to Figure 4:

1. Loosen the *setscrew* (R1) on the *table height adjust handle* (R).
2. Slide the *handle* (R) onto the table bracket *shaft* (C₁).
3. Turn the *handle* (R) until the *setscrew* (R1) is on the flat section of the *shaft* (C₁) and tighten the *setscrew* (R1) with a 3mm hex wrench to secure the handle.
4. Thread the *column lock handle* (K) into the back side of the *table bracket* (C) opposite the *height adjust handle* (R).

6.4 Mounting the head

1. With the aid of a second person, carefully lift *head* onto *column top* (Figure 5).

CAUTION The head assembly is heavy. To avoid injury and/or damage to equipment, lift head onto column only with additional assistance.

2. Rotate head assembly until sides of *belt cover* (A₁) are parallel with sides of *base* (D, Figure 3).
3. Tighten two *set screws* (A₂, Figure 5) with a 5mm wrench until they are snug.

6.5 Installing handles

Refer to Figures 5 and 6:

Install three *handles* (F) into *downfeed-hub* (A₃) as shown. Tighten using provided wrench on the flat of the handles.

Install remaining handle (F, Figure 6) on speed adjust hub on opposite side of head.

6.6 Installing chuck and arbor

1. Adjust position of table to approximately seven inches below *spindle assembly* (A₄, Figure 5) and lock in place.

Refer to Figure 6:

2. Thoroughly clean *spindle* (A₄), *arbor* (G), and *chuck* (O).

Important: These three pieces must be free of any rust protection, or lubricant. If they are not clean and dry, the arbor and chuck will fail to seat in the spindle.

3. Place *arbor* (G) into *chuck* (O).
4. Open chuck all the way to completely retract the chuck jaws.
5. Place arbor and chuck assembly into *spindle* (A₄).
6. Rotate arbor and chuck assembly until *tang* (G₁) on arbor engages the slot at end of spindle.
7. Place a scrap board against bottom of chuck, and firmly tap the board two or three times with a mallet or hammer, to seat the arbor.

6.7 Mounting to bench

Before operating, the assembled drill press must be securely mounted to a bench or stand, using appropriate fasteners (not provided) through the two holes in the base.

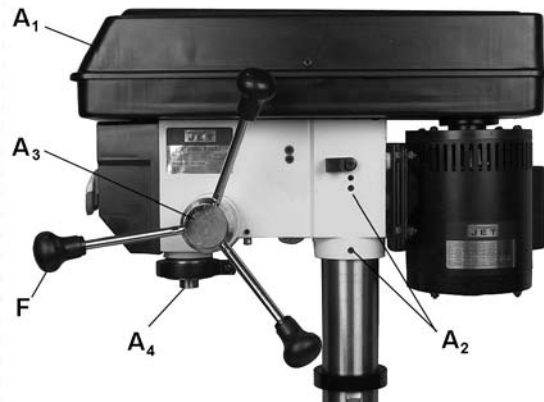

Figure 5

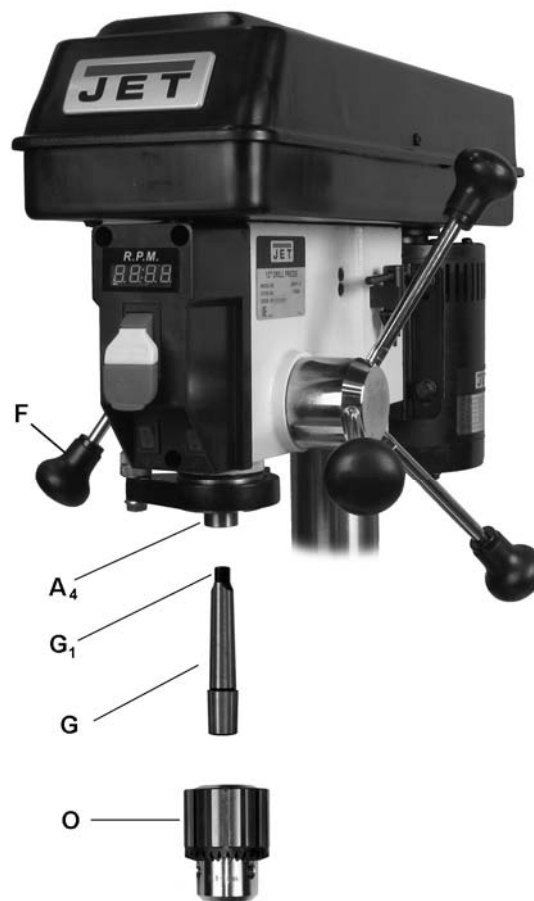

Figure 6

7.0 Electrical connections

⚠WARNING All electrical connections must be done by a qualified electrician in compliance with all local codes and ordinances. Failure to comply may result in serious injury.

The JWDP-12 is rated at 115-volt power. The drill press comes with a plug designed for use on a circuit with a *grounded outlet* that looks like the one pictured in **A**, Figure 7.

Before connecting to power source, be sure switch is in *off* position.

It is recommended that the drill press be connected to a dedicated 15 amp circuit with circuit breaker or fuse. If connected to a circuit protected by fuses, use time delay fuse marked "D". **Local codes take precedence over recommendations.**

7.1 GROUNDING INSTRUCTIONS

This machine must be grounded. In the event of a malfunction or breakdown, grounding provides a path of least resistance for electric current to reduce the risk of electric shock. This tool is equipped with an electric cord having an equipment-grounding conductor and a grounding plug. The plug must be plugged into a matching outlet that is properly installed and grounded in accordance with all local codes and ordinances.

Do not modify the plug provided - if it will not fit the outlet, have the proper outlet installed by a qualified electrician.

Improper connection of the equipment-grounding conductor can result in a risk of electric shock. The conductor with insulation having an outer surface that is green with or without yellow stripes is the equipment-grounding conductor. If repair or replacement of the electric cord or plug is necessary, do not connect the equipment-grounding conductor to a live terminal.

⚠WARNING Check with a qualified electrician or service personnel if the grounding instructions are not completely understood, or if in doubt as to whether the tool is properly grounded. Failure to comply may cause serious or fatal injury.

Use only 3-wire extension cords that have 3-prong grounding plugs and 3-pole receptacles that accept the tool's plug.

Repair or replace damaged or worn cord immediately.

115 Volt operation only

This tool is intended for use on a circuit that has an outlet that looks like the one illustrated in **A**, Figure 7. An adapter, shown in **B** and **C**, may be used to connect this plug to a 2-pole receptacle as shown in **B** if a properly grounded outlet is not available. The temporary adapter should be used only until a properly grounded outlet can be installed by a qualified electrician. *This adapter is not permitted in Canada.* The green-colored rigid ear, lug, and the like, extending from the adapter must be connected to a permanent ground such as a properly grounded outlet box.

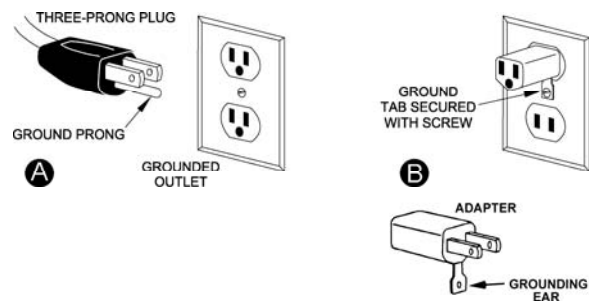

Figure 7

7.2 Extension cords

Make sure your extension cord is in good condition. When using an extension cord, be sure to use one heavy enough to carry the current your machine will draw. An undersized cord will cause a drop in the line voltage resulting in power loss and overheating. The table below shows the correct size to use depending on the cord length and nameplate ampere rating. If in doubt, use the next heavier gauge. Remember, the smaller the gauge number, the heavier the cord.

Cord Length	AWG
0 – 25ft	16
5 – 50ft	14

8.0 Adjustments

8.1 Removing chuck and arbor

Refer to Figure 8:

1. Unplug machine from power source.
2. Raise table until it is about seven inches below chuck.
3. Place a piece of scrap wood on the table, and lower *quill* (E) using the *downfeed handle* (A).
4. Still maintaining the lowered quill position, rotate spindle to align key hole in spindle with key hole in *quill* (E).
5. Insert *drift key* (D) into the aligned slots and tap lightly. The chuck and arbor assembly should fall from the spindle.

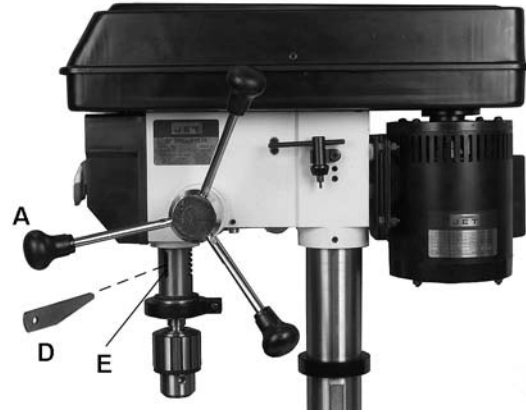

Figure 8

CAUTION Prepare to catch the chuck and arbor as it drops. Striking the floor could damage the tool.

8.2 Adjusting depth stop

Refer to Figure 9:

To drill multiple holes at the same preset depth, use the depth stop as follows:

1. Use a pencil to *mark* (A) the depth the bit will drill into the workpiece.
2. With the drill bit in the chuck, lower *downfeed handle* (B) to advance bit to your *mark* (A).
3. With your other hand, advance the lower *lock nut* (D) on the depth stop rod until it is snug to the *seat* (C). Tighten upper lock nut against lower lock nut (D).
4. The drill bit will now advance to this point.
5. To release, advance the nuts counter-clockwise to the top of the depth stop.

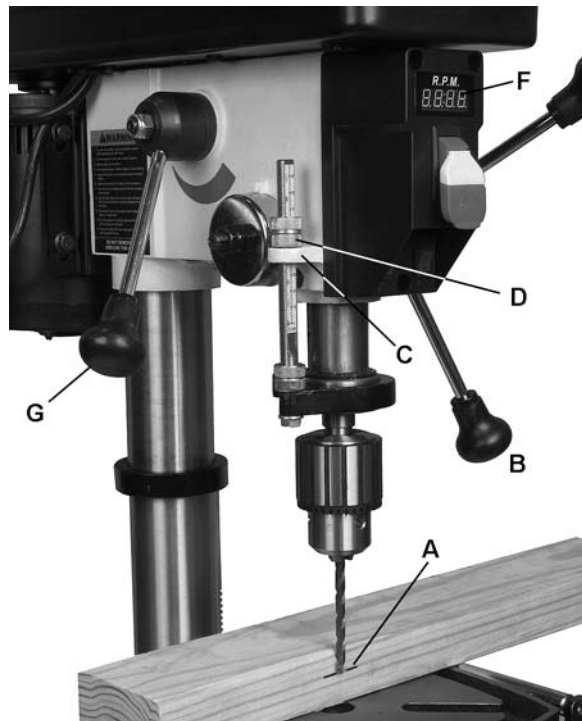

Figure 9

8.3 Spindle speed adjust

Refer to Figure 9:

Adjust spindle speed by changing position of *spindle speed adjust lever* (G). The actual speed is shown on the *LED display* (F).

The drill press must be turned on when making this adjustment. Moving the *lever* (G) towards the front increases the spindle speed while moving the lever back will decrease speed from a range of 530 RPM to 3100 RPM.

8.4 Return spring adjustment

The *return spring* is located opposite the *downfeed handle hub* and sets the tension for the downfeed handle. It is adjusted at the factory and should not need further adjustment.

If adjustment is deemed necessary:

1. Unplug machine from power source.

Refer to Figure 10:

2. Loosen *jam nut* (A) and *hex nut* (B). Do not remove.
3. Pull out slightly the *coil spring cover* (C) while firmly holding it. DO NOT allow the coil spring cover to turn freely in your hand, or the spring will unwind.
4. Rotate the coil spring cover (C) until notch on cover engages with *tab* (E) on head casting. Turn cover clockwise to decrease tension and counter-clockwise to increase tension.
5. Tighten *hex nut* (B) firmly **by hand** against cover (C), then secure by tightening *jam nut* (A) against hex nut (B).

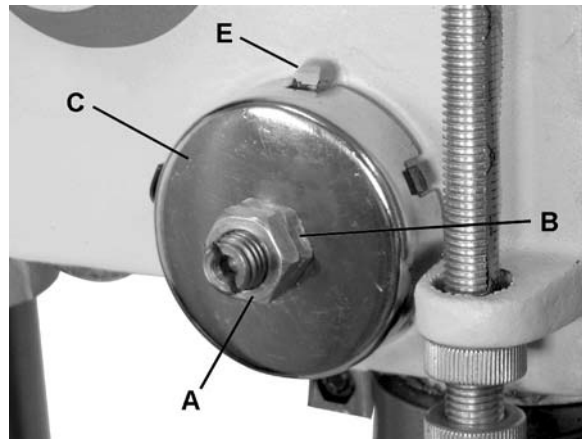

Figure 10

8.5 Laser adjustment

The Laser Assembly has been installed and preset at the factory. It should, however, be checked and any adjustments made before operating the drill press. It should also be rechecked periodically, as constant machine use may cause it to become misaligned.

To align (refer to Figure 11):

1. Place a small *drill bit* (D) in the *chuck* (C), then place *board* (F) flat on the table. Do not allow the board to move from this position; use clamps if needed. **Important:** The drill press table should be in horizontal position and locked.
2. Bring the bit down until it leaves a *slight perforation* in the board (E) then raise it back up.
3. Connect power to drill press, and turn on laser using button at front of drill press head.
4. Using a 3mm hex wrench, loosen *setscrews* (A) on both laser assemblies (only left side laser assembly is shown in Figure 11).
5. Adjust (B) so the *laser line* (G) crosses the perforation (E). Tighten *setscrew* (A).
6. Adjust the other laser assembly in the same manner until both laser lines form *cross-hairs* (G,H) exactly over the *perforation* (E) in the board.
7. Tighten both setscrews (A).

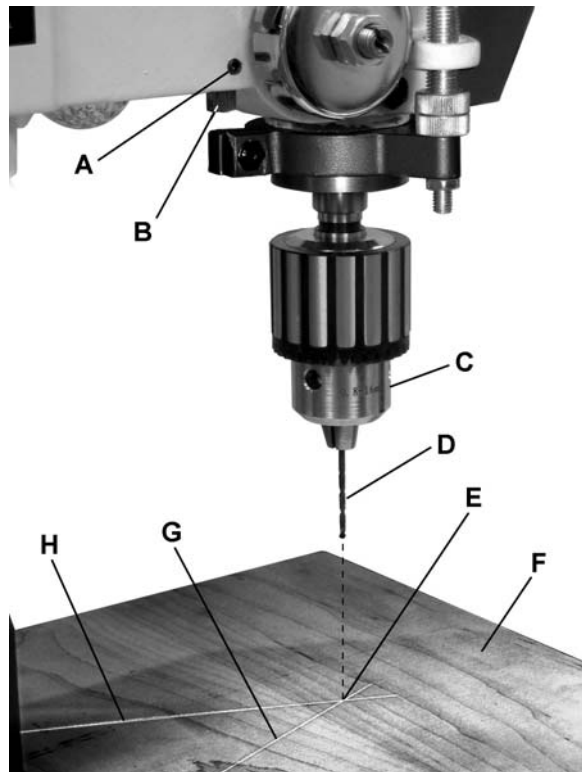

Figure 11

The laser is now calibrated properly and the location of your holes can be centered at the crosshairs for accurate drilling.

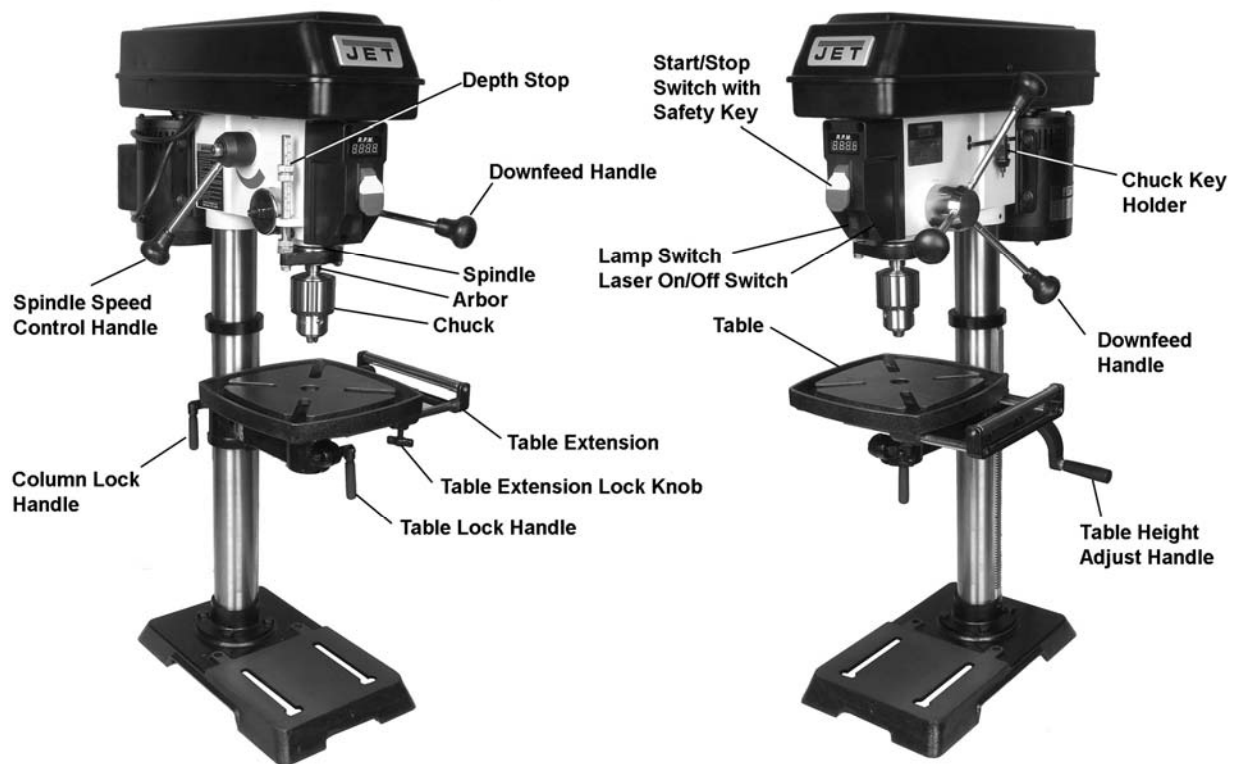

Figure 12

9.0 Features and controls

Refer to Figure 12:

Downfeed Handle – Lower and raise spindle.

Lamp Switch – Turns lamp on and off.

Laser Switch – Turns laser on and off.

Spindle Speed Control Handle – Used to set spindle speed from 530 to 3100RPM. Machine must be on when making adjustment.

Start/Stop Switch – Pull switch to start; push to stop. Remove key (yellow) to prevent machine from being started. Key can be removed while machine is in operation, but machine will not restart until key is reinserted.

Table Height Adjust Handle – Raises and lowers table; column lock handle must be unlocked.

Table Lock Handle – Unlocking permits rotation of table.

10.0 Lubrication

Periodically lubricate the gear and the rack, the table elevation mechanism, the splines (grooves) in the spindle, and the teeth of the quill with #2 tube grease.

11.0 Basic operation

- Always use a back-up piece of scrap wood to cover the table. This protects both the table and the drill bit.
- Place material to be drilled in such a way as to come into contact with the left side of the column. This prevents the material from spinning.

WARNING If the work piece is not large enough to come into contact with the column, use a clamp or drill press vise that is securely fastened to the table. Failure to comply may cause serious injury.

- Feed the bit into the material with only enough force to allow the drill bit to work. Feeding too slowly may cause burning of the workpiece. Feeding too quickly may cause the motor to stop and/or the drill bit to break.

Generally speaking, the smaller the drill bit, the greater the RPM required. Wood requires higher speeds than metal. Metal is usually drilled at slower speeds.

- In dusty environments, frequently blow out any dust that accumulates inside the motor.

12.0 Troubleshooting JWDP-12 Drill Press

Symptom	Possible Cause	Correction *
Drill press will not start.	Drill press unplugged from wall or motor.	Check all plug connections.
	Fuse blown or circuit breaker tripped.	Replace fuse or reset circuit breaker.
	Cord damaged.	Replace cord.
	Starting capacitor bad.	Replace starting capacitor.
Drill press does not come up to speed.	Extension cord too light or too long.	Replace with adequate size and length cord.
	Low current.	Contact a qualified electrician.
Drill Press vibrates excessively.	Stand on uneven surface.	Adjust stand so that it rests evenly on floor.
	Bad belt(s).	Replace belts.
Noisy Operation.	Incorrect belt tension.	Adjust belt tension.
	Dry spindle.	Lubricate spindle.
	Loose spindle pulley.	Check tightness of retaining nut on pulley and tighten if necessary.
	Loose motor pulley.	Tighten set screws in pulleys.
Workpiece Burns.	Incorrect Speed.	Change to appropriate speed.
	Chips not clearing from hole or bit.	Retract drill bit frequently to remove chips.
	Dull drill bit.	Resharpen, or replace drill bit.
	Feeding too slowly.	Increase feed rate.
Drill bit wanders.	Bit sharpened incorrectly.	Resharpen bit correctly.
	Bent drill bit.	Replace drill bit.
	Bit or chuck not installed properly.	Reinstall the chuck or bit properly.
Wood splinters on the underside.	No backing board used.	Place a scrap board beneath workpiece to prevent splintering.
Drill bit binds in workpiece.	Workpiece pinching the bit.	Support or clamp workpiece.
	Excessive feed rate.	Decrease feed rate.
	Chuck jaws not tight.	Tighten chuck jaws.
	Improper belt tension.	Increase belt tension.
Excessive drill bit run out, or wobble.	Bent drill bit.	Replace drill bit
	Worn spindle bearings.	Replace spindle bearings.
	Bit or chuck not properly installed.	Reinstall the bit or chuck properly.
Quill returns too slow, or too fast.	Spring has improper tension.	Adjust return spring.
Chuck or arbor does not stay in place.	Dirt, grease, etc on arbor, chuck, or spindle.	Clean all mating surfaces thoroughly with a cleaner degreaser.

* **WARNING:** Some corrections may require a qualified electrician.

13.0 Replacement parts

13.1.1 JWDP-12 Drill Press – Exploded View

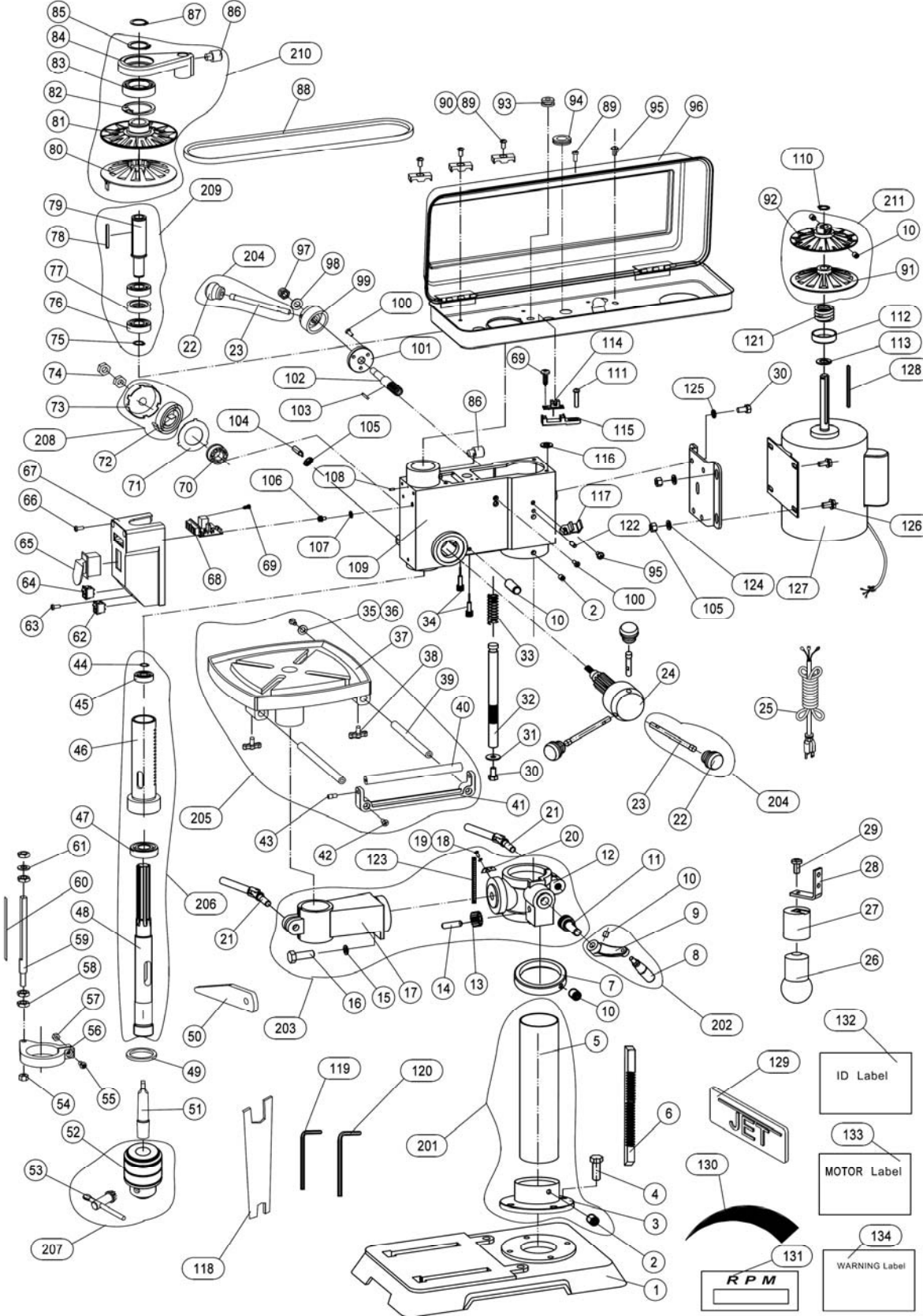

13.1.2 JWDP-12 Drill Press – Parts List

To order parts or reach our service department, call 1-800-274-6848 Monday through Friday, 8:00 a.m. to 5:00 p.m. CST. Having the Model Number and Serial Number of your machine available when you call will allow us to serve you quickly and accurately.

Index No	Part No	Description	Size	Qty
1	JWDP12-001	Base		1
201	JWDP12-201	Column Assembly (#2 thru 5)		1
2	TS-1524011	Socket Set Screw	M8x8	3
3	JWDP12-003	Column Support		1
4	TS-1491031	Hex Cap Screw	M10x25	4
5	JDP12-27	Column		1
6	JDP12-26	Rack		1
7	JWDP12-007	Rack Collar		1
202	JWDP12-202	Crank Arm Handle Assembly (#8 thru 10)		1
8	JWDP12-008	Crank Arm Handle Grip		1
9	JWDP12-009	Crank Arm Shaft		1
10	TS-1523031	Socket Set Screw	M6x10	6
203	JWDP12-203	Table Support Assembly (#11 thru 20, and 123)		1
11	JWDP12-011	Worm Shaft		1
12	JDP12-19	Table Support		1
13	JWDP12-013	Helical Gear		1
14	JWDP12-014	Gear Pin		1
15	TS-2361121	Spring Washer	12mm	1
16	TS-1492031	Hex Cap Screw	M12x35	1
17	JDP12-9	Table Arm		1
18	TS-2284082	Phillips Screw	M4x8	2
19	TS-2361041	Spring Washer	4mm	2
20	JWDP12-020	Tilt Scale		1
21	JWDP12-021	Lock Handle		2
204	JWDP12-204	Handle Assembly (#22 and 23)		4
22	JWDP12-022	Handle		4
23	JWDP12-023	Knob		4
24	JWDP12-024	Pinion Shaft		1
25	JWDP12-025	Power Cord		4
26	JDP12-48	LED Bulb	115V/1.3W	1
27	JWDP12-027	Lamp Socket		1
28	JWDP12-028	Lamp Socket Bracket		1
29	TS-2283102	Phillips Screw	M3x10mm	1
30	TS-1490011	Hex Cap Screw	M8x12	4
31	TS-1550061	Flat Washer	8mm	1
32	JWDP12-032	Rack shaft		1
33	JWDP12-033	Spring		1
34	JWDP12-034	Laser		2
205	JWDP12-205	Table Assembly (#35 thru 43)		1
35	TS-1534042	Phillips Screw	M6x12	1
36	TS-1550061	Flat Washer	8mm	1
37	JWDP12-037	Table		1
38	JWDP12-038	Locking Knob		2
39	JWDP12-039	Guide Bar		2
40	JWDP12-040	Roller		1
41	JWDP12-041	Roller Support		1
42	TS-1514011	Socket Head Flat Screw	M6x12	2
43	JWDP12-043	Roller Screw		2
206	JWDP12-206	Spindle Assembly (#44 thru 48)		1
44	JWDP12-044	Circlip for shaft	C-11	1
45	BB-6201V	Bearing	6201RZ	1
46	JWDP12-046	Quill		1
47	BB-6204RZ	Bearing	6204RZ	2
48	JWDP12-048	Spindle		1
49	JWDP12-049	Rubber Washer		1

Index No	Part No	Description	Size	Qty
50	JWDP12-050	Drift Key		1
51	JWDP12-051	Chuck Arbor		1
207	JWDP12-207	Chuck Assembly (#52 and 53)		1
52	JDP12-30	Chuck		1
53	JWDP12-053	Chuck Key		1
54	TS-1540061	Hex Nut	M8	1
55	TS-1534052	Phillips Screw	M6x16	1
56	JWDP12-056	Lock Collar		1
57	TS-1540041	Hex Nut	M6	1
58	JWDP12-058	Special Hex Nut		4
59	JWDP12-059	Depth Stop Bolt		1
60	JWDP12-060	Depth Scale		1
61	JWDP12-061	Special washer		1
62	JWDP12-062	Switch for Lamp		1
63	TS-1533032	Phillips Screw	M5x10	1
64	JWDP12-064	Switch for Laser		1
65	JDP12-90	On/Off Switch		1
	JDP12-90-1	Switch Safety Key		1
66	TS-1533042	Phillips Screw	M5x14	2
67	JWDP12-067	Switch Box		1
68	JWDP12-068	Digital Read Out		1
69	JWDP12-069	Self-Tapping Screw	ST2.9x6.5	4
70	JWDP12-070	Bushing		1
71	JWDP12-071	Spring Retainer		1
208	JWDP12-208	Coil Spring Assembly (#72 and 73)		1
72	JWDP12-072	Coil Spring		1
73	JWDP12-073	Spring Housing		1
74	JWDP12-074	Thin Hex Nut	M12	2
209	JWDP12-209	Drive Sleeve Assembly (# 75 thru 79)		1
75	F006045	External Retaining Ring	17mm	1
76	BB-6203V	Ball Bearing	6203RZ	2
77	JWDP12-077	Spacer		1
78	JWDP12-078	Key	A4x4x64	1
79	JWDP12-079	Drive Sleeve		1
210	JWDP12-210	Spindle Pulley Assembly (#80 thru 86)		1
80	JWDP12-080	Spindle Pulley, Lower		1
81	JWDP12-081	Spindle Pulley, Upper		1
82	JWDP12-082	Retaining Ring	55mm	1
83	BB-61907RZ	Ball Bearing	61907RZ	1
84	JWDP12-084	Bracket		1
85	F006033	Internal Retaining Ring	35mm	1
86	TS-1524031	Set Screw	M8X12	2
87	F006049	External Retaining Ring	24mm	1
88	JWDP12-088	Belt	M36 (O-La900)	1
89	TS-1533042	Phillips screw	M5x12	4
90	JWDP12-090	Cord Pressure Plate		3
211	JWDP12-211	Motor Pulley Assembly (#91, 92 and 10)		1
91	JWDP12-91	Motor Pulley, Lower		1
92	JWDP12-92	Motor Pulley, Upper		1
93	JWDP12-093	Grommet A		1
94	JWDP12-094	Grommet B		3
95	TS-1482021	Phillips screw	M6x12	5
96	JWDP12-096	Pulley Cover		1
97	JWDP12-097	Lock Nut	M10	1
98	JWDP12-098	Washer		1
99	JWDP12-099	Hub		1
100	JWDP12-100	Phillips Screw	M5x10	5
101	JWDP12-101	Shaft Plate		1
102	JWDP12-102	Shaft		1
103	JWDP12-103	Key	A3x3x25	1
104	JWDP12-104	Quill Set Screw	M8	1

Index No	Part No	Description	Size	Qty
105	TS-1540061	Hex Nut	M8	5
106	JWDP12-106	Phillips Screw	M5x8	2
107	TS-2193051	Internal Tooth Lock Washer	5mm	2
108	JWDP12-108	Pin	5x13	1
109	JWDP12-109	Headstock		1
110	JVM836-47	Retaining Ring	C-14	1
111	JWDP12-111	Phillips Screw	M4x20	2
112	JWDP12-112	Spring Cover		1
113	JWDP12-113	Motor Washer		1
114	JWDP12-114	Counter	120V 3.5V	1
115	JWDP12-115	Counter Base		1
116	JWDP12-116	Sponge Pad		4
117	JWDP12-117	Chuck Key Holder		1
118	JWDP12-118	Wrench		1
119	TS-152704	Hex Wrench S3	S-3	1
120	TS-152705	Hex Wrench S4	S-4	1
121	JWDP12-121	Motor Pulley Spring		1
122	JWDP12-122	Pin	6x15	2
123	JWDP12-123	Angle Scale		1
124	TS-152706	Flat Washer	8mm	4
125	TS-2361081	Spring Washer	8mm	3
126	TS-1490021	Hex Cap Screw	M8x16	4
127	JWDP12-127	Motor Assembly	1/3HP, 115V, 1Ph	1
	JWDP12-127SC	Starting Capacitor (not shown)	150 μ F, 125V	1
	JWDP12-127CC	Capacitor Cover (not shown)		1
	JWDP12-127CS	Centrifugal Switch (not shown)		1
128	JWDP12-128	Key	A4x4x80	1
129	JET-92	Jet Logo	92x38mm	1
130	LM000139	Speed Control Label		1
131	LM000140	RPM Label		1
132	LM000141	ID Label		1
133	LM000142	Motor Label		1
134	LM000143	Warning Label		1

14.0 Electrical connections – JWDP-12

1 Phase, 115V only

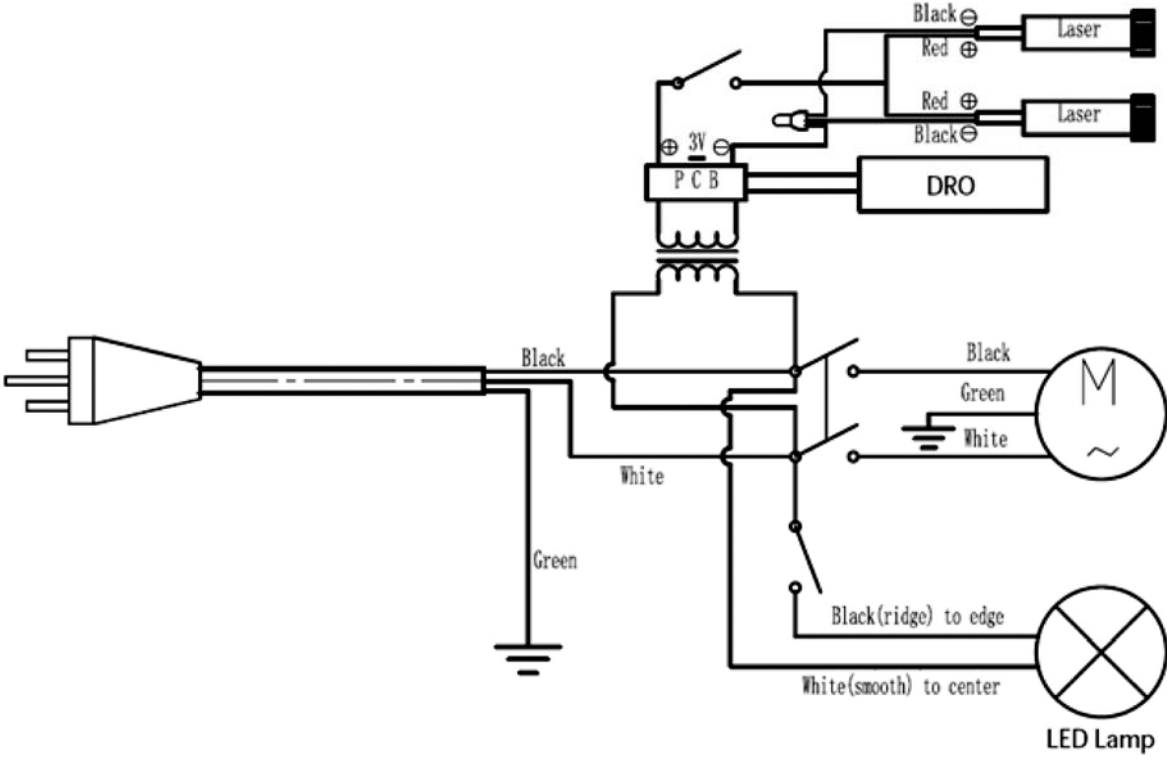

15.0 Warranty and Service

JET warrants every product it sells against manufacturers' defects. If one of our tools needs service or repair, please contact Technical Service by calling 1-800-274-6846, 8AM to 5PM CST, Monday through Friday.

Warranty Period

The general warranty lasts for the time period specified in the literature included with your product or on the official JET branded website.

- JET products carry a limited warranty which varies in duration based upon the product. (See chart below)
- Accessories carry a limited warranty of one year from the date of receipt.
- Consumable items are defined as expendable parts or accessories expected to become inoperable within a reasonable amount of use and are covered by a 90 day limited warranty against manufacturer's defects.

Who is Covered

This warranty covers only the initial purchaser of the product from the date of delivery.

What is Covered

This warranty covers any defects in workmanship or materials subject to the limitations stated below. This warranty does not cover failures due directly or indirectly to misuse, abuse, negligence or accidents, normal wear-and-tear, improper repair, alterations or lack of maintenance. JET woodworking machinery is designed to be used with Wood. Use of these machines in the processing of metal, plastics, or other materials outside recommended guidelines may void the warranty. The exceptions are acrylics and other natural items that are made specifically for wood turning.

Warranty Limitations

Woodworking products with a Five Year Warranty that are used for commercial or industrial purposes default to a Two Year Warranty. Please contact Technical Service at 1-800-274-6846 for further clarification.

How to Get Technical Support

Please contact Technical Service by calling 1-800-274-6846. **Please note that you will be asked to provide proof of initial purchase when calling.** If a product requires further inspection, the Technical Service representative will explain and assist with any additional action needed. JET has Authorized Service Centers located throughout the United States. For the name of an Authorized Service Center in your area call 1-800-274-6846 or use the Service Center Locator on the JET website.

More Information

JET is constantly adding new products. For complete, up-to-date product information, check with your local distributor or visit the JET website.

How State Law Applies

This warranty gives you specific legal rights, subject to applicable state law.

Limitations on This Warranty

JET LIMITS ALL IMPLIED WARRANTIES TO THE PERIOD OF THE LIMITED WARRANTY FOR EACH PRODUCT. EXCEPT AS STATED HEREIN, ANY IMPLIED WARRANTIES OF MERCHANTABILITY AND FITNESS FOR A PARTICULAR PURPOSE ARE EXCLUDED. SOME STATES DO NOT ALLOW LIMITATIONS ON HOW LONG AN IMPLIED WARRANTY LASTS, SO THE ABOVE LIMITATION MAY NOT APPLY TO YOU.

JET SHALL IN NO EVENT BE LIABLE FOR DEATH, INJURIES TO PERSONS OR PROPERTY, OR FOR INCIDENTAL, CONTINGENT, SPECIAL, OR CONSEQUENTIAL DAMAGES ARISING FROM THE USE OF OUR PRODUCTS. SOME STATES DO NOT ALLOW THE EXCLUSION OR LIMITATION OF INCIDENTAL OR CONSEQUENTIAL DAMAGES, SO THE ABOVE LIMITATION OR EXCLUSION MAY NOT APPLY TO YOU.

JET sells through distributors only. The specifications listed in JET printed materials and on official JET website are given as general information and are not binding. JET reserves the right to effect at any time, without prior notice, those alterations to parts, fittings, and accessory equipment which they may deem necessary for any reason whatsoever. JET® branded products are not sold in Canada by JPW Industries, Inc.

Product Listing with Warranty Period

90 Days – Parts; Consumable items
1 Year – Motors; Machine Accessories
2 Year – Metalworking Machinery; Electric Hoists, Electric Hoist Accessories; Woodworking Machinery used for industrial or commercial purposes
5 Year – Woodworking Machinery
Limited Lifetime – JET Parallel clamps; VOLT Series Electric Hoists; Manual Hoists; Manual Hoist Accessories; Shop Tools; Warehouse & Dock products; Hand Tools; Air Tools

NOTE: JET is a division of JPW Industries, Inc. References in this document to JET also apply to JPW Industries, Inc., or any of its successors in interest to the JET brand.



427 New Sanford Road
LaVergne, Tennessee 37086
Phone: 800-274-6848
www.jettools.com