

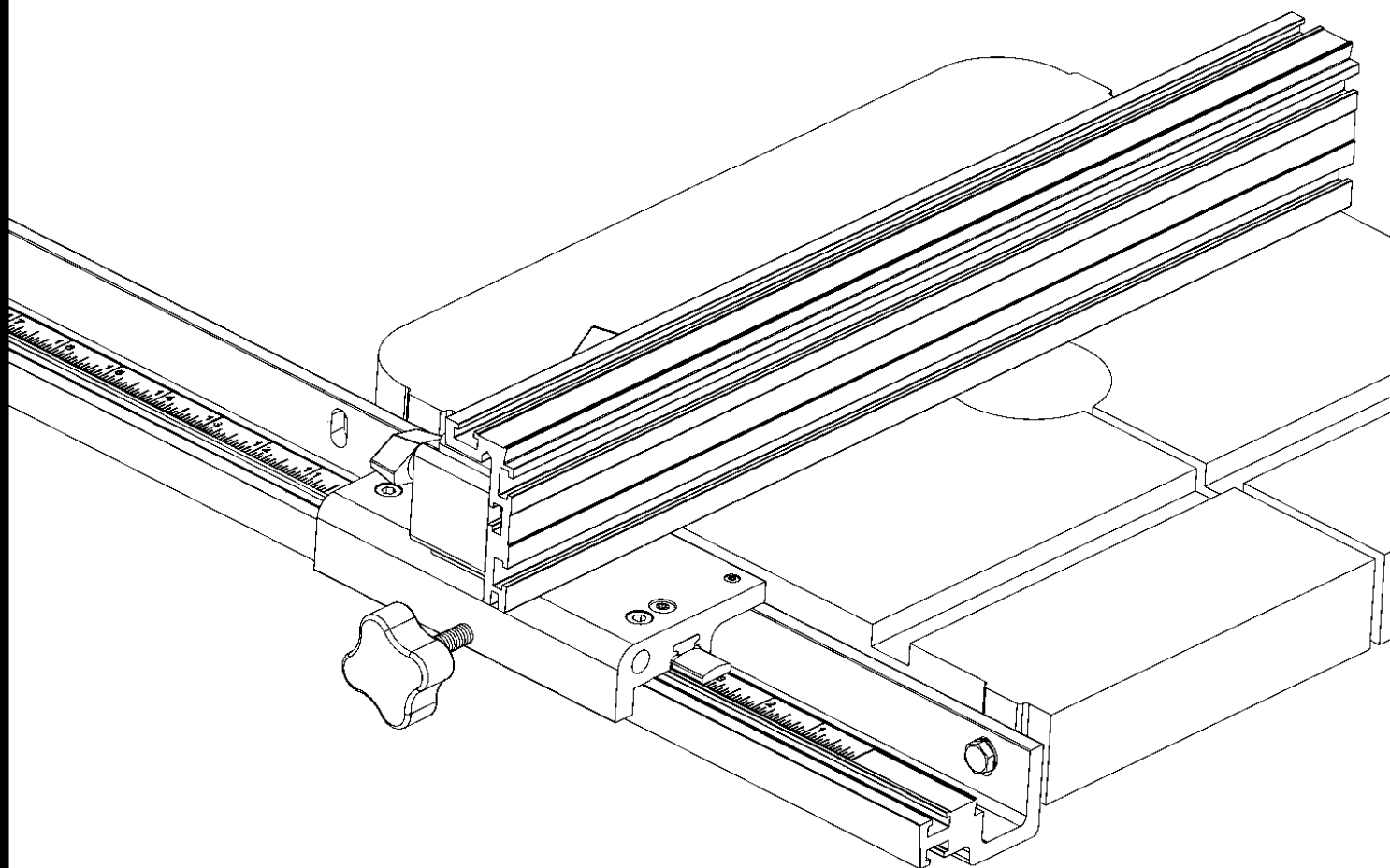

Precision Band Saw Fence KM57200

INSTRUCTIONAL MANUAL



 **The Blue Mark of Quality.**

(Revision 20041201)

RTD1000010AA

Congratulations on choosing a Kreg Precision Band Saw Fence!

Be sure to read the instructions and the safety warnings completely before using this tool.

Table of Contents

<i>TABLE OF CONTENTS</i>	1
<i>SAFETY GUIDELINES</i>	2-3
<i>PARTS DIAGRAM</i>	4
<i>INSTALLING THE MOUNTING RAIL</i>	5
<i>DRILLING THE MOUNTING RAIL</i>	6
<i>ASSEMBLING THE CLAMPING BLOCK</i>	6
<i>ATTACHING THE BAND SAW TRAK</i>	7
<i>ATTACHING THE MEASURING TAPE</i>	8
<i>ADJUSTING PARALLELISM</i>	8
<i>ADJUSTING FOR BLADE DRIFT</i>	9
<i>WARRANTY</i>	10

2 *Safety Guidelines*

Kreg™ *Precision Band Saw Fence Guidelines*

Thank you for purchasing KREG components. All products have been designed to ensure safe and efficient operation when installed and used properly. We think you will agree that our Precision Band Saw Fence is the best currently available.

Warning

- Woodworking machines are dangerous and can cause personal injury if not used properly.
- Read safety instructions and operating instructions for your machine completely before using products. Using this system before understanding its safe and proper use could result in serious injury to the operator.
- Warning: Failure to follow these rules may result in serious personal injury.
- For your own safety, read instruction manual before operating the tool. Learn the tools application and limitations as well as the specific hazards peculiar to it.
- Keep all guards and safety devices in proper place while using these products.
- Always wear safety glasses.
- Keep hands well away from the rotating blade when operating machine.
- Avoid awkward hand positions, where a sudden slip could cause contact with rotating blade. Never reach behind the rotating blade with either hand to clear the area of debris.

Kickbacks

Beware of kickbacks; they can cause serious injury. A kickback occurs when the workpiece binds up while being cut, causing it to twist, jump, or become airborne.

To avoid kickbacks:

- Always use sharp band saw blades.
- Keep machine in proper alignment and good working condition.
- Work must always be held securely against the table and fence.
- Keep guides in their proper position and in good working order.
- Always support longer boards on both the infeed side and the outfeed side of the blade.

Warranty

- Kreg components are fully guaranteed for one year from date of purchase.
- Kreg will replace or repair, at no charge to the customer, any product that fails within the warranty period.
- Kreg will service Kreg components beyond the warranty period at a reasonable cost to customer.
- Any neglect, misuse or usage of the Tools in a fashion not recommended by Kreg will void all warranties.

As with all machinery, there are certain hazards involved with operation and use of the band saw. Using the machine with respect and caution will considerably lessen the possibility of personal injury. However, if normal safety precautions are overlooked or ignored, personal injury to the operator may result.

This system was designed for certain applications only. Kreg strongly recommends that this system NOT be modified and/or used for any application other than for which it was designed. If you have any questions relative to its application, DO NOT use the Tools until you have written Kreg Tool and we have advised you.

Safety Guidelines

To avoid injury, never adjust the fence along the mounting rail or position of the HD Trak while the band saw is running. Make sure the blade comes to a complete stop before removing the workpiece.

Ground all tools. If tool is equipped with three-prong plug, it should be plugged into a three-hole electrical receptacle. If an adapter is used to accommodate a two-prong receptacle, the adapter lug must be attached to a known ground. Never remove the third prong.

Lock down all knobs. Form habit of checking to see that the lock down knob is fully tightened and the HD Trak T-knobs are secure prior to starting the band saw.

Don't use in dangerous environment. Don't use power tools in damp or wet locations, or expose them to rain. Keep work area well-lighted.

Keep children and visitors away. All children and visitors should be kept a safe distance from work area.

Make workshop CHILD PROOF with padlocks, master switches, or by removing starter keys.

Don't force tool. It will do the job better and be safer at the rate for which it was designed.

Use right tool. Don't force tool or attachment to do a job for which it was not designed.

Wear proper apparel. No loose clothing, gloves, neckties, rings, bracelets, or other jewelry to get caught in moving parts. Nonslip foot wear is recommended. Wear protective hair covering to contain long hair.

Don't overreach. Keep proper footing and balance at all times.

Maintain tools in top condition. Keep tools sharp and clean for best and safest performance.

Follow instructions for lubricating and changing accessories.

Disconnect tools before servicing and when changing blades and installing accessories such as this fence.

Use recommended accessories. The use of improper accessories may cause hazards.

Avoid accidental starting. Make sure switch is in "OFF" position before plugging in power cord.

Never stand on tool. Serious injury could occur if the tool is tipped or if the cutting tool is accidentally contacted.

Check damaged parts. Before further use of the tool, a guard or other part that is damaged should be carefully checked to ensure that it will operate properly and perform its intended function. Check for alignment of moving parts, binding of moving parts, breakage of parts, mounting, and any other conditions that may affect its operation. A guard or other part that is damaged should be properly repaired or replaced.

Never leave tool running unattended. Turn power off. Don't leave tool until it comes to a complete stop.

Drugs, alcohol, medication. Do not operate tool while under the influence of drugs, alcohol or any medication.

Make sure tool is disconnected. from power supply while installing the Precision Band Saw Fence.



KREG TOOL COMPANY
201 Campus Drive
Huxley, Iowa 50124

4 Parts Diagram

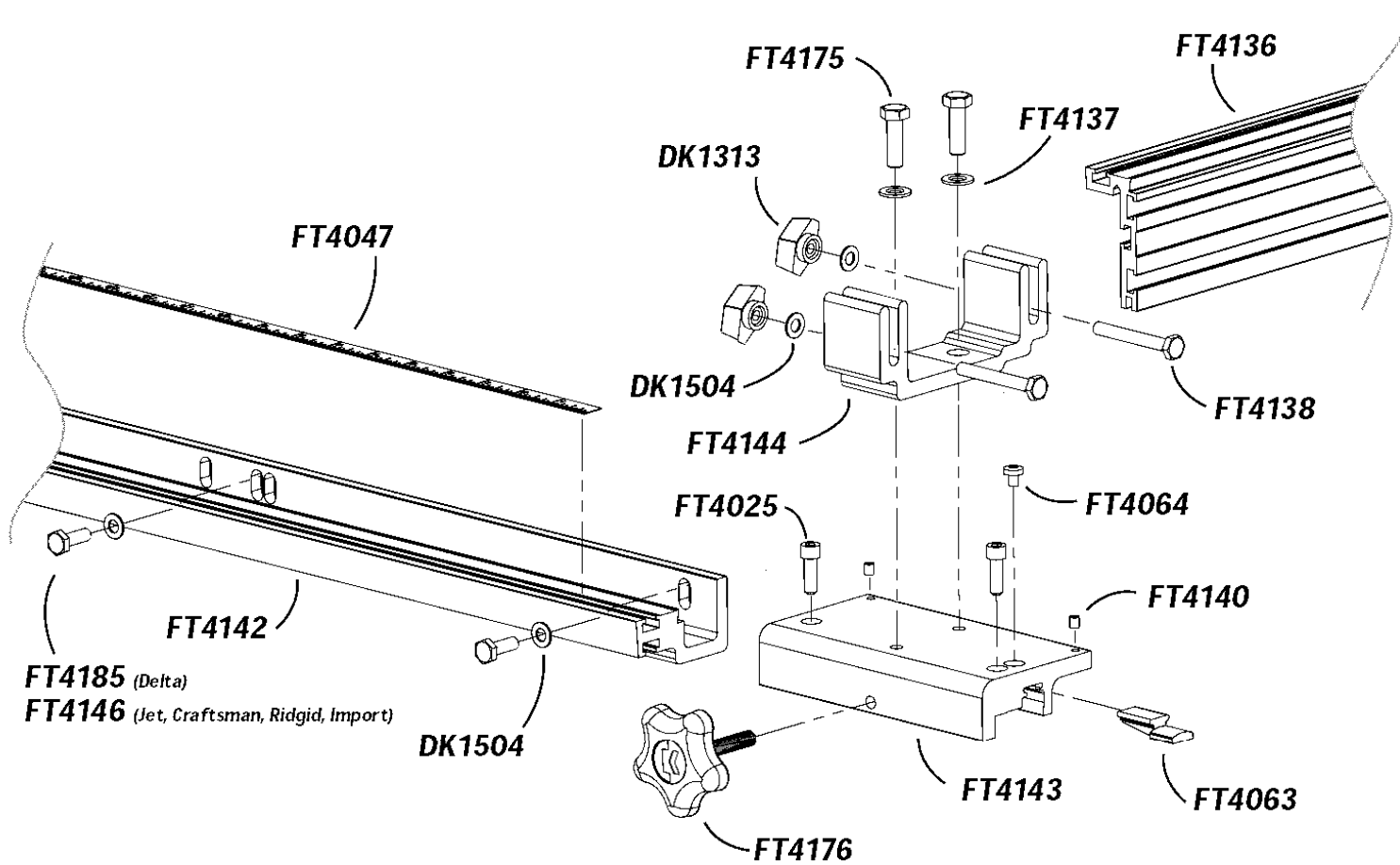

Part Number	Quantity	Description
DK1313	2	Black T-Knob
DK1504	4	1/4" Brass Washers
FT4025	2	1/4-20 x 3/4" Nylon Set Screw
FT4047	1	Right to Left Reading Self-Adhesive Tape
FT4063	1	Lens Cursor
FT4064	1	10-32 x 1/4" Nylon Screw
FT4136	1	18" Band Saw HD Trak
FT4137	2	5/16" Brass Washer
FT4138	2	1/4-20 x 2-1/2" Hex Bolt
FT4140	2	10-32 x 3/8" Nylon Set Screw
FT4142	1	Band Saw Mounting Rail
FT4143	1	Band Saw Clamp Block
FT4144	1	Band Saw Adapter Bracket
FT4185	2	1/4-28 x 1-1/4" Hex Bolt (Delta Mount)
FT4146	2	M6 x 1 x 30mm Hex Bolt (Jet, Craftsman, Ridgid and Import Mount)
FT4175	2	5/16" x 3/4" Hex Head Bolt
FT4176	1	Lock Down Knob

Installing the Mounting Rail

Choose the set of slots that corresponds to the band saw where you are installing the Band Saw Fence. Vertical slots are used so that the fence rail can be properly aligned with several different band saws with holes in their tables at different heights in relationship with the table surface. Refer to Fig. 1 to see which slots are for your saw. If you do not see your saw listed, hold the Mounting Rail up to table edge of your saw and find a set of holes that match the mounting holes in your table edge. Many manufactures share holes so there may be a set of holes pre-drilled in the Mounting Rail that match your saw. If it is necessary that you drill the Mounting Rail to accommodate hole spacing other than the slots provided we strongly suggest using the existing slot on the right of the Mounting Rail so that there is less chance for error. For further explanation of drilling the Mounting Rail refer to the "Drilling the Mounting Rail" section.

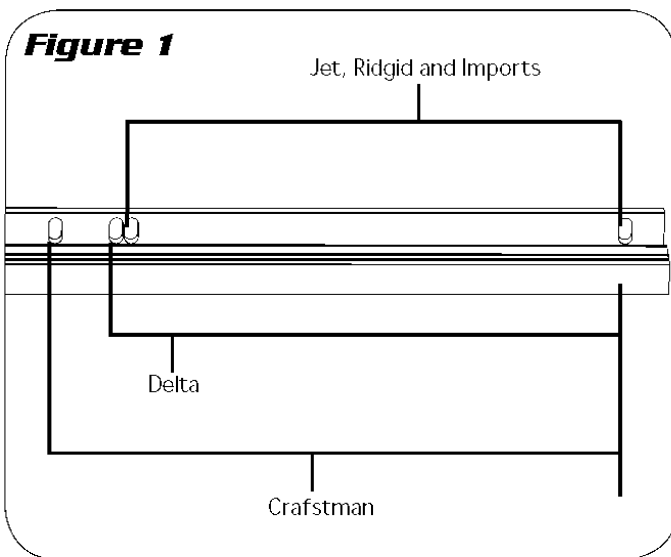

Once the slots that you will be using have been identified, next choose the bolts that match the threaded holes in your band saw table edge. These threaded holes are very similar across all models so great care should be taken to choose the correct bolts. Each set of mounting bolts can be identified by the size of wrench that fits the head. The M6 bolts used with Jet, Craftsman, Ridgid, and many other import models require a 10mm wrench. The 1/4-28 bolts used on Delta models require a 7/16" wrench.

Tip

The mounting holes on your band saw may contain debris making it difficult to thread in the mounting bolts. Thread the mounting bolts by hand into the mounting holes prior to assembly clearing any debris and ensuring the bolts will thread properly when installing the mounting rail. If the bolts will not thread fully you may need to clean the threads with a corresponding tap. Consult your owner's manual to make certain you use the correct size. You may need to contact the manufacturer for complete details.

Start with the right hole, placing a washer on a bolt, pushing the bolt through the slot, and then begin threading the bolt into the hole in the table edge while supporting the rail with the other hand. Do not tighten the right bolt at this time. Now swing the rail into position, pushing the bolt with washer through the slot, and begin threading that bolt into the left hole in the table edge while supporting the rail with the other hand.

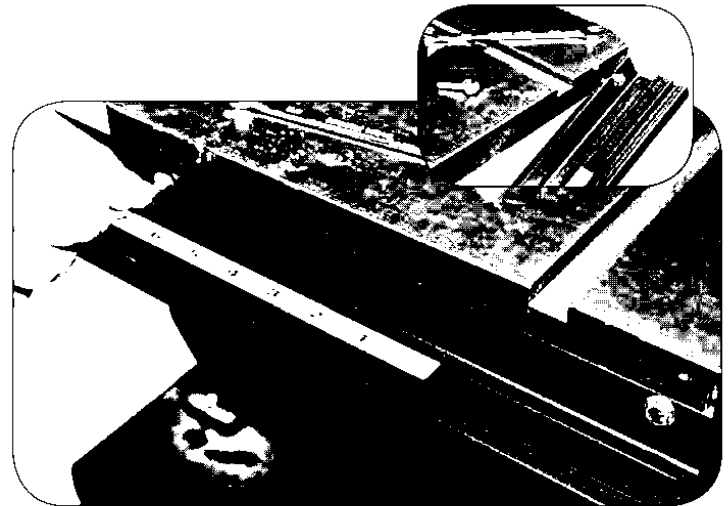

Start bolt in right-side hole, then swing into position and secure left bolt.

The Kreg Precision Band Saw Fence has been designed to be used in conjunction with the miter gauge slot. To take advantage of this feature measure the depth of the miter gauge slot and align the top of the Mounting Rail just slightly below the bottom of the miter gauge slot.

Tip

Use a combination square to align the Mounting Rail slightly below the miter gauge slot. Simply set the blade of the combination square first to the miter gauge slot depth, then adjust the blade to an out length slightly longer than that measurement. The combination square may then be used to set each side of the Mounting Rail.

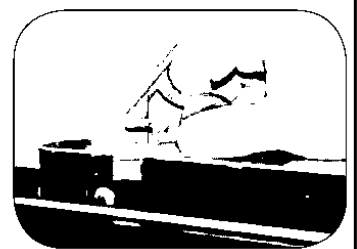
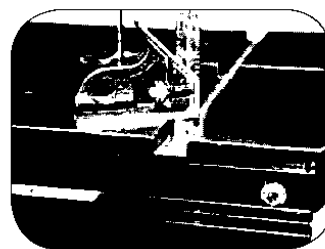

Snug the left bolt against the Mounting Rail with the top of the Mounting Rail at the proper depth in relationship with the table surface. Then raise the right side of the Mounting Rail to set the top of the right side of the Mounting Rail to the proper depth and tighten the right side mounting bolt. Check the top of the left side of the Mounting Rail again then tighten the left mounting bolt.

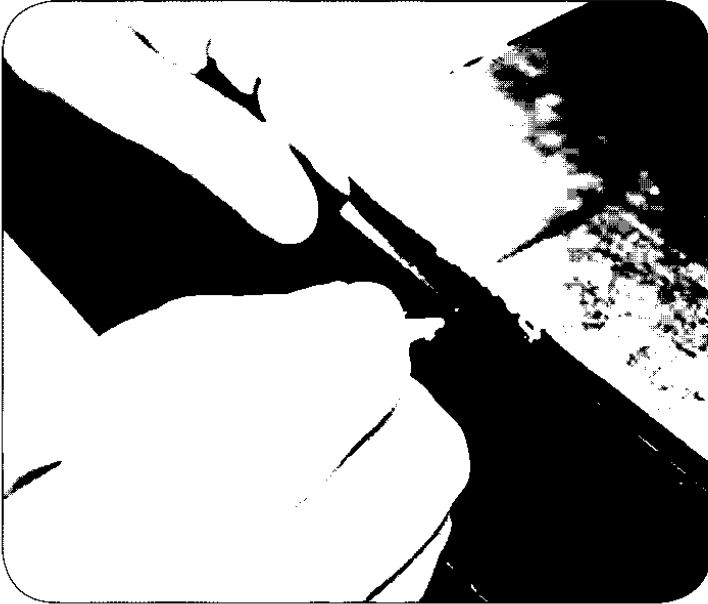

Apply marks to the table on center with the mounting hole prior to installation and transfer those marks to the Mounting Rail.

Drilling the Mounting Rail

Although the Mounting Rail does not have pre-drilled slots for every band saw in existence a vast majority of the band saws in use are covered by the slots that have been provided. If you find that a pair of slots already machined into the Mounting Rail will not mate with the holes pre-drilled in your band saw table then it will be necessary to drill one hole in the Mounting Rail to facilitate installation. Follow the previous steps for assembly but instead of threading the left bolt into the table mark the hole location for the left bolt by performing one of the following operations. Use a pencil or marker to go through the mounting hole from the inside of the table flange to the back of the Mounting Rail or apply marks to the table on center with the mounting hole prior to installation and transfer those marks to the Mounting Rail. Be certain to use a center punch to prevent the drill bit from wandering and also use an oversized hole to allow for any misalignment during installation. Your experience with an installation that requires the drilling of an additional hole can greatly benefit those that purchase the Band Saw Fence at a later date. If you would please give us a call at (800) 446-8638 to tell us what brand and model band saw that you have and the specific hole location required. Our staff as well as future Kreg Tool customers would appreciate your findings.

Assembling the Clamping Block

The Clamp Block is the heart of the Kreg Precision Band Saw Fence. The Clamp Block locks firmly to the Mounting Rail with a twist of the Lock Down Knob to provide a rock-solid platform to support the HD Trak forming the Band Saw Fence. The "Double-Dovetail" design of the anchoring system performs effortlessly, virtually eliminating misalignment. The Clamp Block contains the Lens Cursor which acts as the "brains" of the system working in conjunction with the Measuring Tape to produce precise, repeatable cuts every time. Small nylon set-screws are located in the front of the Clamp Block to allow the Clamp Block to glide smoothly along the Mounting Rail.

Another pair of larger set-screws is located toward the rear of the Clamp Block and these set-screws can be adjusted to maintain parallelism between the HD Trak and the blade. The Adapter Bracket transfers the horizontal clamping action along the Mounting Rail to the vertical surface of the HD Trak and the fence itself. The Adapter Bracket is machined so that it will allow the user to adjust the Band Saw Fence for blade drift. Last but not least the Clamping Block is machined to accept an optional Micro-Adjuster accessory to "dial in" cuts with micrometer precision.

Refer to Fig. 2

1. Insert the Lens Cursor into the Clamp Block and hold in place with the 10-32 x 1/4" Nylon Screw. Adjusting the position of the red-line cursor will be outlined in the **"Attaching the Measuring Tape"** section.
2. Thread two 10-32 x 3/8" Nylon Set Screws into the forward portion of the top surface of the Clamp Block. Adjust the set screws to protrude just slightly below the bottom surface of the Clamp Block.
3. Thread two 1/4-20 x 3/4" Nylon Allenhead Screws into the rear portion of the top surface of the Clamp Block. Adjustment of these set screws will be outlined in the **"Adjusting Parallelism"** section.
4. Place a 5/16" Brass Washer on each of the 5/16" x 3/4" Hex Head Bolts and insert through the Adapter Bracket into the Clamp Block. Make sure that the larger hole in the Adapter Bracket faces forward with the smaller hole toward the Lock Down Knob. Align the Adapter Bracket square with the Clamp Block for now and tighten both bolts. Adjusting the Adapter Bracket for blade drift will be discussed in the **"Adjusting for Blade Drift"** section.
5. Thread the Lock Down Knob into the front vertical surface of the Clamp Block. Adjust the Lock Down Knob to allow the swivel pad to be just slightly proud of the inside surface.
6. Set the Clamp Block assembly on the Mounting Rail and lightly tighten the Lock Down Knob to hold the assembly in place for further assembly.

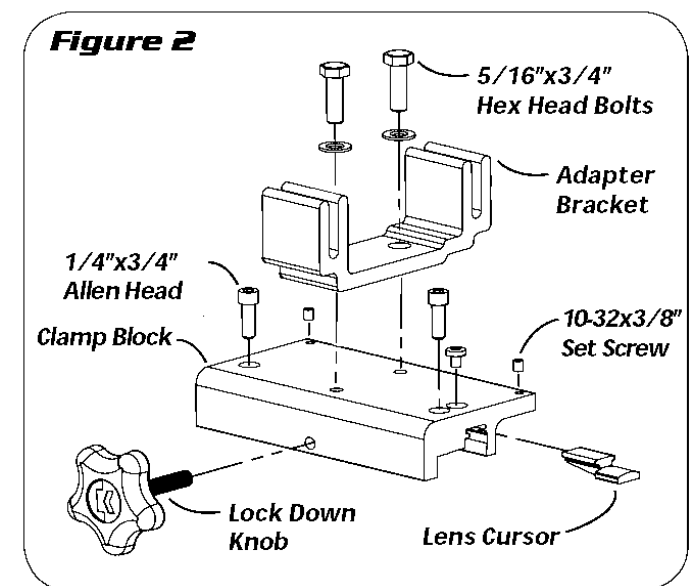

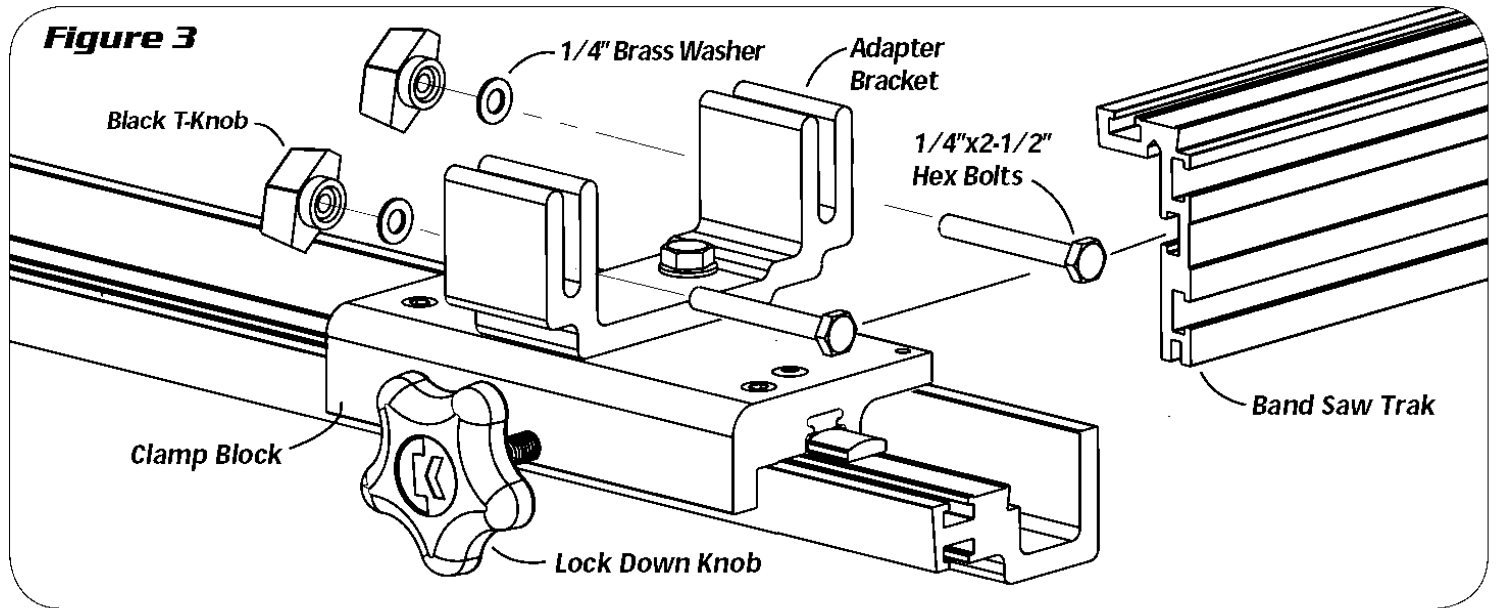

Attaching the Band Saw Trak

Refer to Fig. 3

The Trak attaches to the Clamp Block via the Adapter Bracket. These parts are designed in such a way that the fence may be used on either side of the blade. In addition to this feature the Trak may be positioned anywhere along the Adapter Bracket. By loosening the anchoring bolts and simply sliding the Trak along the face of the Adapter Bracket the Trak can be positioned forward for situations where additional support is required in front of the blade. This unique mounting system will also allow the user to rotate the Trak 90° to create a Low Profile fence. Maximum guide support is maintained while making narrow cuts where the fence would normally interfere with the guide system.

1. Insert the head of each of the 1/4-20 x 2-1/2" bolts into the single groove of the inside face of the Band Saw Trak.
2. Align these bolts to fit into the openings of the Adapter Bracket uprights. Lower the Trak along the face of the Adapter Bracket until the Trak is supported by the band saw table surface and the Adapter Bracket.
3. Place a 1/4" Brass Washer on each bolt and follow with the Black T-Knob. A rigid connection between the Clamp Block and the Trak is formed after tightening the Black T-Knobs.
4. Test the operation of the Band Saw Fence by sliding it back and forth along the Mounting Rail.

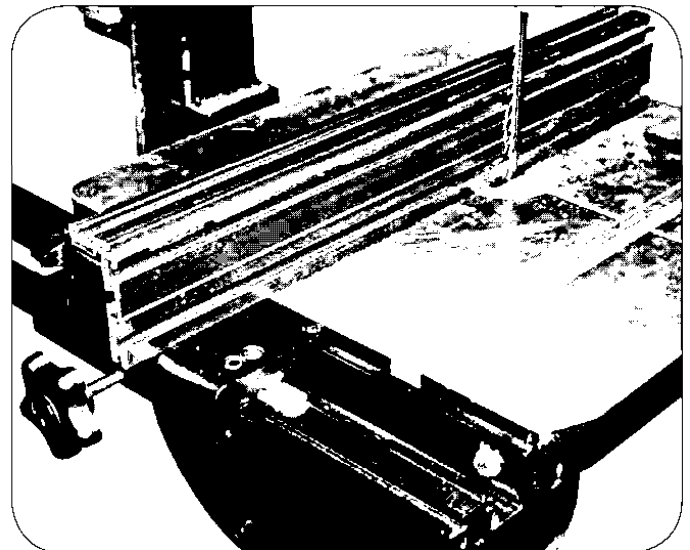

Regular cutting position

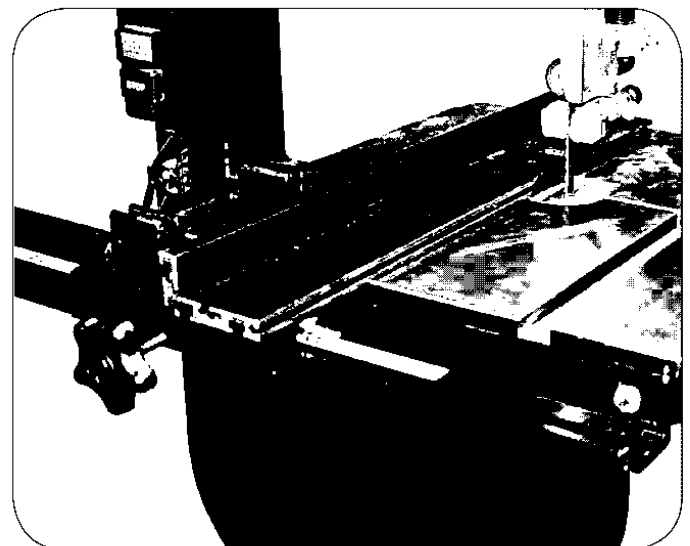

Low profile position of fence allows blade guard to be lowered

Tip

An effortless movement of the fence to the left and right can be obtained by tightening the Lock Down Knob to "pull" the fence square with the double-dovetail locking mechanism then backing-off the Lock Down Knob ever-so-slightly. Experiment with the position of the Lock Down Knob to attain the smoothness you desire when positioning the fence

Attaching the Tape

The Measuring Tape on the Kreg Precision Band Saw Fence will transform your band saw into a woodworking machine capable of exact cuts and repeatable accuracy.

1. Position the fence against the blade making sure the fence is touching but not deflecting the blade.
2. Use a pencil to scribe a line on the Mounting Rail above and below the red line on the Lens Cursor. Remove the Fence and Clamp Block assembly from the Mounting Rail by loosening the Lock Down Knob and pushing forward on the Clamp Block until the double-dovetail surfaces disengage lifting the assembly off the Mounting Rail.
3. Peel the backing away from the Self-Adhesive Measuring Tape exposing about an inch of the "sticky" side of the tape. Place the Measuring Tape in the shallow groove provided on the Mounting Rail aligning the "Zero" mark on the Measuring Tape with the pencil lines you scribed on the Mounting Rail. Once the first inch of the Measuring Tape is in place pull the remaining backing from under the Measuring Tape pressing firmly along the length of the tape till it covers the entire length of the Mounting Rail. Trim the Measuring Tape to fit the Mounting Rail. Reinstall the Fence and Clamp Block assembly on the Mounting Rail and check the red line of the Lens Cursor against the "Zero" mark on the Measuring Tape. You can "re-zero" the red line by loosening the screw that holds the Lens Cursor in place and readjust the Lens Cursor if necessary.

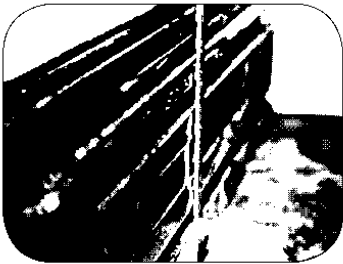

1. Position fence against the blade

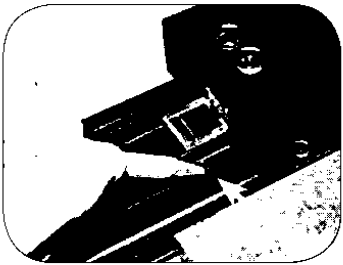

2. Use a pencil to scribe a line on the Mounting Rail above and below the red line on the Lens Cursor



3. Align mark on tape to your pencil scribe. Peel away backing to apply adhesive tape

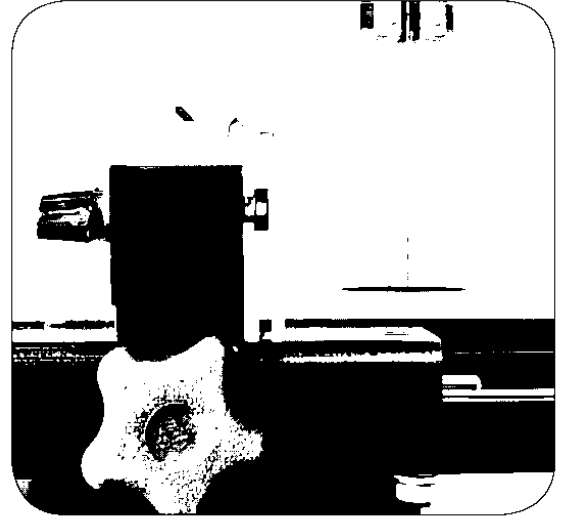

The Kreg Precision Band Saw Fence is equipped with set screws to make minor adjustments to the fence so that the vertical surface of the HD Trak is exactly parallel with the blade.

Adjusting Parallelism

The Kreg Precision Band Saw Fence is equipped with set screws to make minor adjustments to the fence so that the vertical surface of the HD Trak is exactly parallel with the blade. Be certain that the unparallel surfaces between the blade and fence are not the result of a table that is not square to the blade. Refer to the instructions provided by the band saw manufacturer for information on how to align the table square to the blade. If you still feel it is necessary to make this adjustment begin by threading the rear set screws in the Clamp Block down till they contact the surface of the Mounting Rail. Once these set screws touch the Mounting Rail surface either the left screw or the right screw may be adjusted to align the "face" of the fence parallel with the blade.

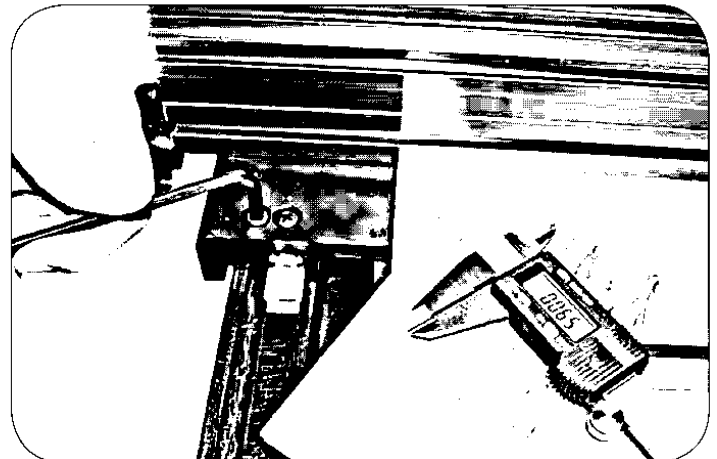

Either the left screw or the right screw may be adjusted to align the "face" of the fence parallel with the blade.

Tip

Reserve the parallel adjustment for thin cuts where even the smallest difference between the top and bottom of the cut are noticeable. These cuts may include material removal from tenons and dovetailing operations. This adjustment is also very beneficial for adjusting the fence to eliminate tapered pieces when cutting veneers.

Tip

If you fold the backing under the measuring tape toward the bottom of the markings at a 90° angle it will be easier to peel the remaining backing from under the Measuring Tape after it is placed in position.

Adjusting for Blade Drift

The Kreg Precision Band Saw Fence will allow the user to align the fence to match a saw blade's "drift angle". You can set the fence to compensate for the drift angle by adjusting the Fence "out of square" with the Clamp Block. Remove the Fence and Clamp Block assembly as described in the previous section. Using a piece of scrap material about 30" long cut to middle of the scrap board. Turn off the saw and hold the scrap board firmly while the saw coasts down. Scribe a line on the table surface of the band saw along either side of the scrap board. Reattach the Fence and Block assembly and locate the fence along the line that was scribed on the table surface. The final alignment can be achieved by loosening both bolts that attach the Adapter Bracket to the Clamp Block and rotating the fence to align it precisely with line scribed on the table surface. Re-tighten the bolts that attach the Adapter Bracket to the Clamp Block.

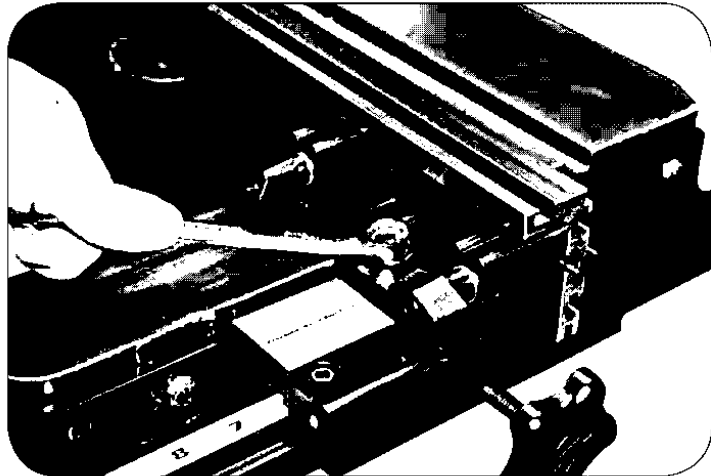

Loosen bolts on adapter bracket to pivot fence for blade drift.

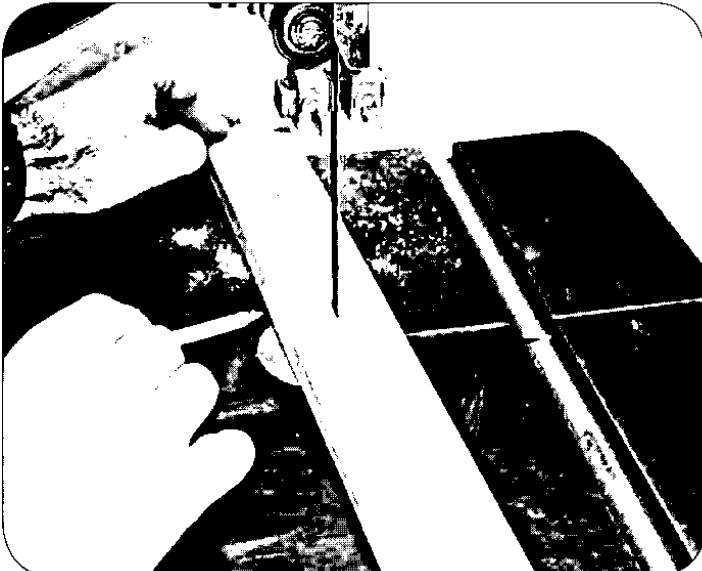

Scribe a line on the table surface of the band saw along either side of the scrap board.

Tip

If you are not able to adjust the fence to the angle necessary to compensate for blade drift then your saw has an excessive amount of drift in the blade. You can minimize the amount of blade drift that a particular saw or saw blade has by adjusting the tracking and the tension currently in place on the band saw. Refer to the instructions provided by the band saw manufacturer for information on how to make these adjustments for your particular band saw

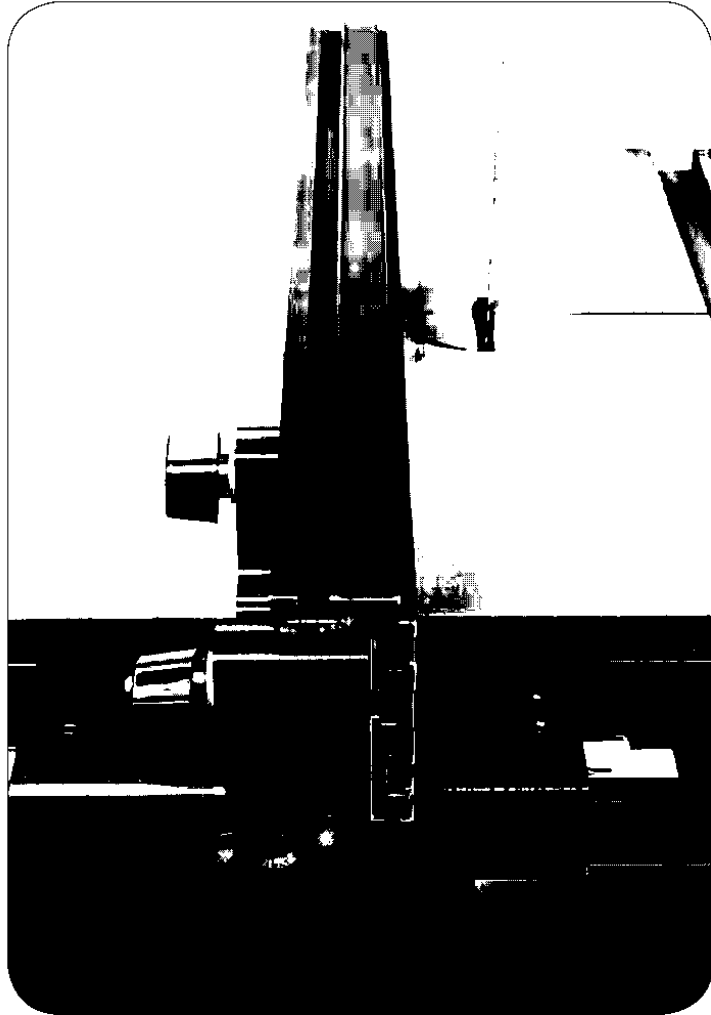

You can set the Fence to compensate for the draft angle by adjusting the Fence "out of square" with the Clamp Block.

Notes

Blank lines for taking notes.

WARRANTY

KREG PRECISION BAND SAW FENCE

Kreg Tool Company warrants to its authorized distributors of Kreg products and the original purchasers from such distributors, the Kreg Precision Band Saw Fence to be free of defects in materials and workmanship for a period of one (1) years from the date of delivery to the original purchaser. During said warranty period Kreg will, at its option, repair or replace any product (or component part thereof) proving defective during said period. This warranty applies only to products which are used in accordance with all instructions as to operation, maintenance and safety set forth in catalogs, manuals, and/or instruction sets furnished by Kreg Tool Company.

This warranty becomes effective only if the accompanying card is fully and properly completed and returned to Kreg Tool Company within ten (10) days from date of delivery to the original purchaser.

This warranty is null and void if the product has been subjected to (1) misuse, abuse or improper service or storage; (2) accident, neglect, damage or other circum-

stances beyond Kreg Tool Company's control; (3) modifications, disassembly, tampering, alterations or repairs outside of Kreg Tool Company's factory not authorized by Kreg Tool Company; and (4) for non-original purchasers. This warranty does not apply to normal wear and tear, corrosion, abrasion, or repairs required due to natural causes or acts of God.

To obtain warranty service contact the distributor from which the Precision Band Saw Fence was purchased, or you may contact Kreg Tool Company directly. Proof of purchase will be required before remedy will be provided under the terms of this warranty. Kreg Tool Company assumes no responsibility for products which are returned without prior authorization. Kreg Tool Company's obligations under this warranty shall be exclusively limited to repairing or replacing (at Kreg Tool Company's option) products which are determined by Kreg Tool Company to be defective upon delivery at Kreg Tool Company's factory, and on inspection by Kreg Tool Company. Under

no circumstance shall Kreg Tool Company be liable for incidental or consequential damages resulting from defective products, nor shall Kreg Tool Company's liability exceed the purchase price paid for the product by the original purchaser.

This is Kreg Tool Company's sole warranty. Any and all other warranties which may be implied by law, including any warranties for merchantability or fitness for a particular purpose, are hereby limited to the duration of this warranty. Kreg Tool Company shall not be liable for any loss, damage or expense directly or indirectly related to the use of its products or from any other cause or for consequential damages (including without limitation, loss of time, inconvenience, and loss of production). The warranty contained herein may not be modified and no other warranty, expressed or implied, shall be made by or on behalf of Kreg Tool Company

Please register your warranty by sending warranty registration card. Warranty service will not be provided without registration.

Keep this form for your records.

For your records the following information will be useful in the event warranty service is required. For complete records attach copy of purchase invoice to this form.

Date of Purchase: ___/___/___

Purchased From: _____



Kreg Tool Company 201 Campus Drive Huxley, IA 50124

Optional Accessories for your Kreg Precision Band Saw Fence

Precision Micro-Adjuster

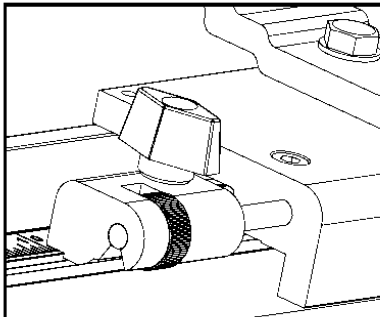

Dial-in precise adjustments to your KREG Band Saw Fence with our Precision Micro-Adjuster.

KMS7215

Re-Saw Guide

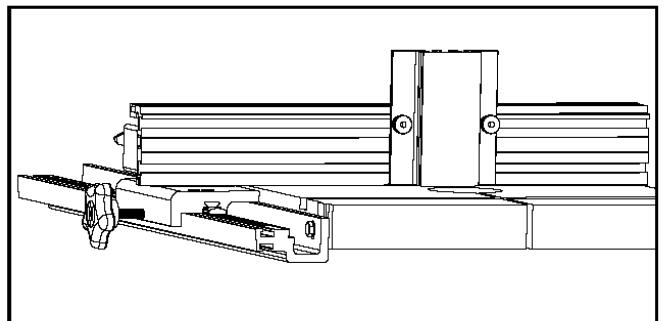

Unique design allows a higher level of control for resawing. Available in both 4½" and 7" sizes.

4 ½" KMS7213
7" KMS7214



PRECISION MEASURING SYSTEMS

Measure Once, Cut Once.

Be sure to visit www.kregtool.com to get all the details surrounding our entire product line.

Solid Production Stop - KMS7800

This "Rock Solid" stop sets the distance from the end of the board and the saw blade for amazing cutting accuracy and repeatability from either side of the blade. Perfect for repetitive, high-production applications.

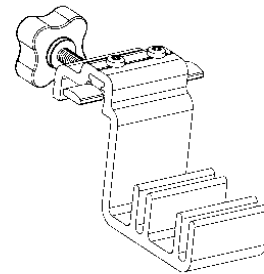

"Perfect Miter" Attachment - KMS7831

This attachment to the KREG stops references a 45 degree mitered board on two surfaces, greatly increasing the cutting accuracy and repeatability of the mitered cut. Great for picture framing.

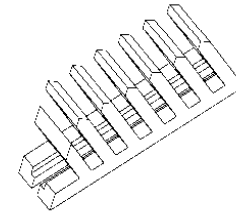

Top Trak - KMS7712 (2') & KMS7714 (4')

Top Trak mounts to the top-side of a shop-made 3/4" thick fence. Accepts the head of a standard 1/4" bolt. Features a self-aligning L-shaped mounting foot for easy installation to a shop-made fence. The top of the trak contains a recess for attaching a 1/2" wide self-adhesive measuring tape sold separately. Trak sections can be butted together to increase fence length.

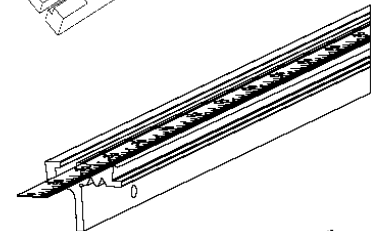

Mini Trak - KMS7506

Mini Trak can be used to produce countless types of woodshop jigs and fixtures such as taper jigs, cutoff sleds, and more. Bottom of trak accepts a 1/2" wide measuring tape to increase accuracy. T-slot will capture the head of any 1/4" hex bolt. Sold in a 4' length with tape. Easily cut to length with a hacksaw.

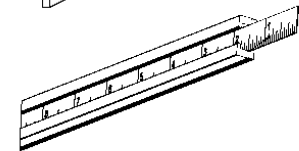

Precision Miter Gauge System - KMS7102

Cut perfect miters consistently with the Precision Miter Gauge System. Features factory calibrated accuracy from a gauge head that is machined on a computerized milling machine. A 24" Heavy Duty Trak section with patented Flipstop and self-adhesive measuring tape is included.

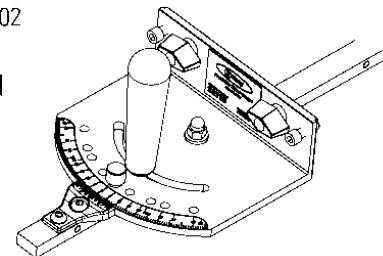

KREG TOOL COMPANY

201 Campus Drive

Huxley, Iowa 50124

www.kregtool.com

800.447.8638

Visit www.kregtool.com today for additional tools, accessories, plans and instructional videos