

## Blum Hinges

### Frameless Box Construction

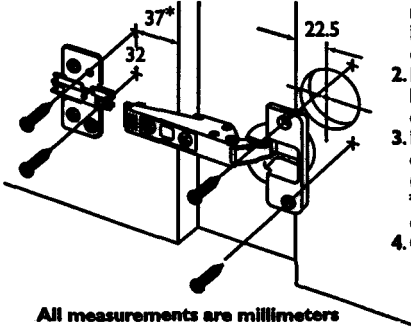

All measurements are millimeters

1. To locate center of hinge cup on back side of door, measure over from edge of door 22.5mm (7/8"). Here drill a 35mm (1-3/8") diameter by 13mm (1/2") deep hole.
2. Insert hinge into 35mm (1-3/8") hole and position hinge so that the arm is perpendicular to edge of door. Screw in place.
3. Next, locate the hinge mounting plate on the front of the cabinet so that the holes are 37mm (1-15/32") from front edge of cabinet.  
\*If door is to have an inset hinge, add the thickness of the door to 37mm. Screw plate to side of cabinet.
4. Clip hinge arm onto mounting plate.

### Full or Half Overlay Application

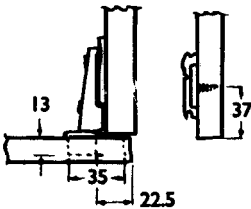

### Inset Application

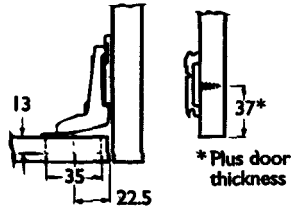

\* Plus door thickness

### Face Frame Hinge

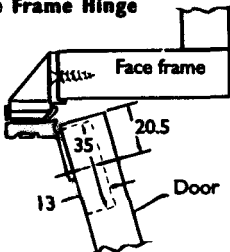

All measurements are millimeters

1. To locate center of hinge cup on back side of door, measure over from edge of door 20.5mm (51/64"). Here bore a 35mm (1-3/8") diameter by 13mm (1/2") deep hole.
2. Insert hinge into 5mm (1-3/8") hole and position hinge so that the arm is perpendicular to edge of door. Screw in place.
3. Next, locate the hinge mounting plate on the face frame and screw into place.
4. Slide arm into mounting plate. Tighten fixing screw.

© 2002 Rockler Companies, Inc.

RTD10301010AA