

Congratulations on the purchase of your Rockler Drill Press Fence! Mount it to a custom shop-built table (see suggested plan inside) for increased accuracy and repeatability, as well as enhanced dust collection. For safe and effective operation, please read these instructions fully before use.

GENERAL SAFETY WARNINGS

This tool is designed for specific applications as defined in the instructions and should not be modified and/or used for any other applications. Before using the Drill Press Fence, read, understand and follow all instructions and safety information provided. **KEEP THESE INSTRUCTIONS FOR FUTURE REFERENCE.**

- > For any tool used in conjunction with this product, always read, understand and follow the instructions and safety warnings for that tool.
- > Before using this product, review and verify that all tools to be used with it have safety equipment installed and are in proper working order as defined by the tools' owner's manuals.
- > Do not use this product until you have read and are confident you understand the:
 - General Safety Warnings;
 - Making a Drill Press Table;
 - Mounting the Table to Your Drill Press.
- > Remain alert and use good judgment when using this tool. Do not use this tool if you are in any way impaired by medications, alcohol, drugs or fatigue.
- > Dress appropriately and remove all jewelry, secure loose clothing and tie up long hair before using this tool.
- > It is the sole responsibility of the purchaser of this tool to ensure that any third party reads and complies with all the instructions and safety precautions outlined in this manual prior to using the tool.
- > Maintain these instructions and warnings as long as you own the tool. Keep this booklet in a place where it will be readily available for reference.
- > The user assumes all risk for the proper use of this tool and for ensuring product suitability for intended application.
- > Always wear safety glasses in compliance with ANSI safety standards and hearing protection and follow all standard shop safety practices including:
 - Keep your work area well lit and clean;
 - Use dust collection tools and dust face masks to reduce exposure to dust;
 - Use accessory safety equipment such as feather boards, push sticks and push blocks whenever appropriate;
 - Do not use power tools in explosive environments (e.g., in the presence of flammable liquids, fumes or dust);
 - Keep children and bystanders away while operating your tools;
 - Maintain proper footing at all times and do not overreach;
 - Do not force the tool;
 - Unplug all power tools before making any adjustments or changing accessories.
- > These warnings and instructions do not represent the total of all information available regarding tool safety, use and technique. Always seek out opportunities to learn more and improve your skills and knowledge.

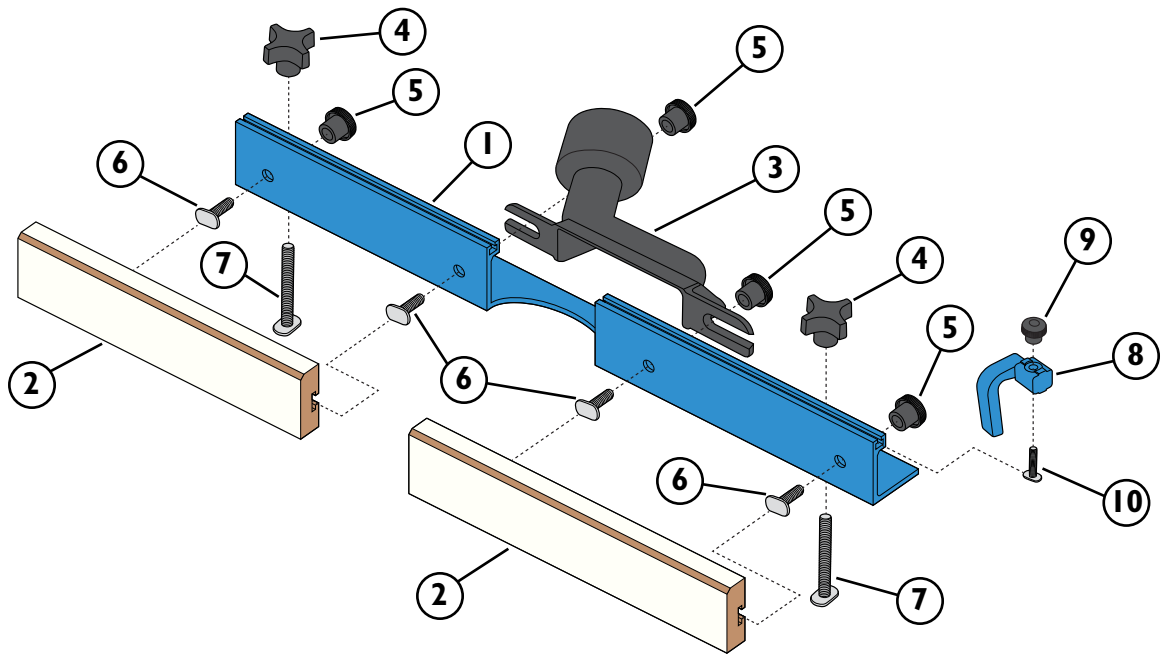

PARTS LIST		Quantity	Quantity
1	Aluminum Fence	1	6 5/16"-18 x 1" T-Bolt
2	12" Adjustable MDF Fence Face	2	7 5/16"-18 x 2 1/2" Fence T-Bolt
3	Dust Port	1	8 2 1/4" Flip Stop
4	4-Star Fence Hold-Down Knob	2	9 1" Round Knob for Flip Stop
5	1" Round Knob	4	10 5/16"-18 x 1 1/2" T-Bolt for Flip Stop

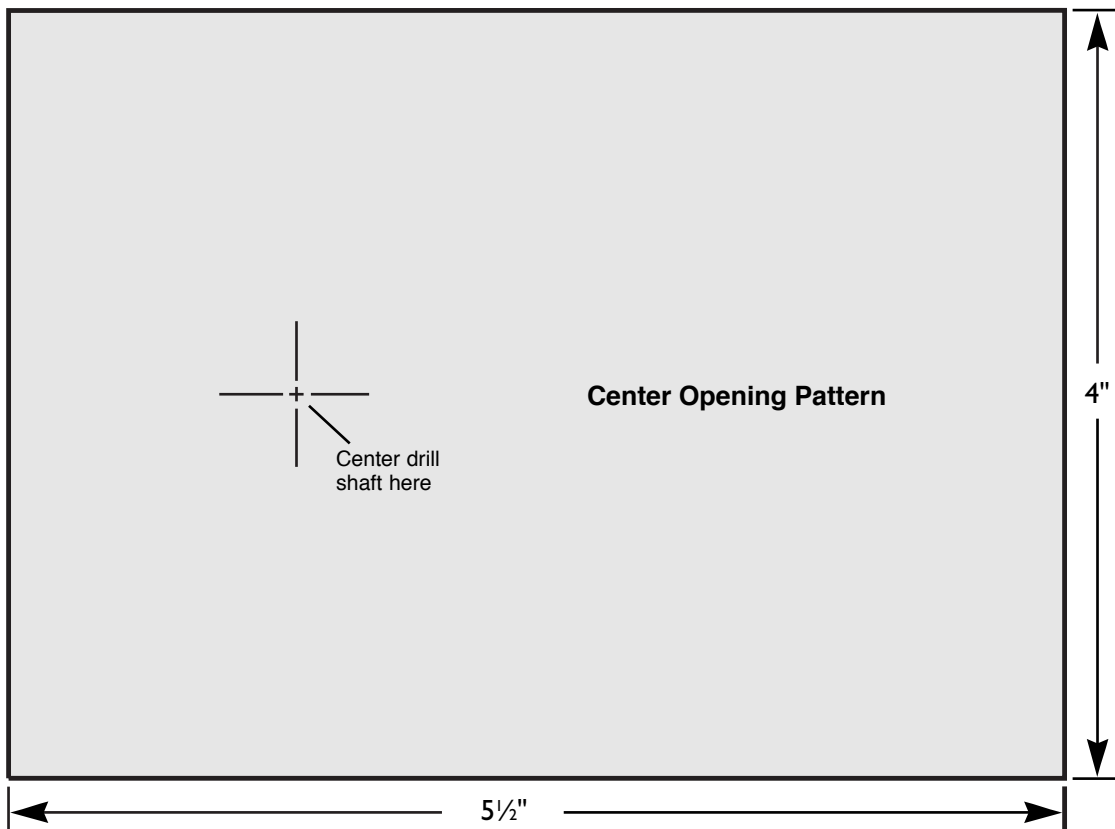

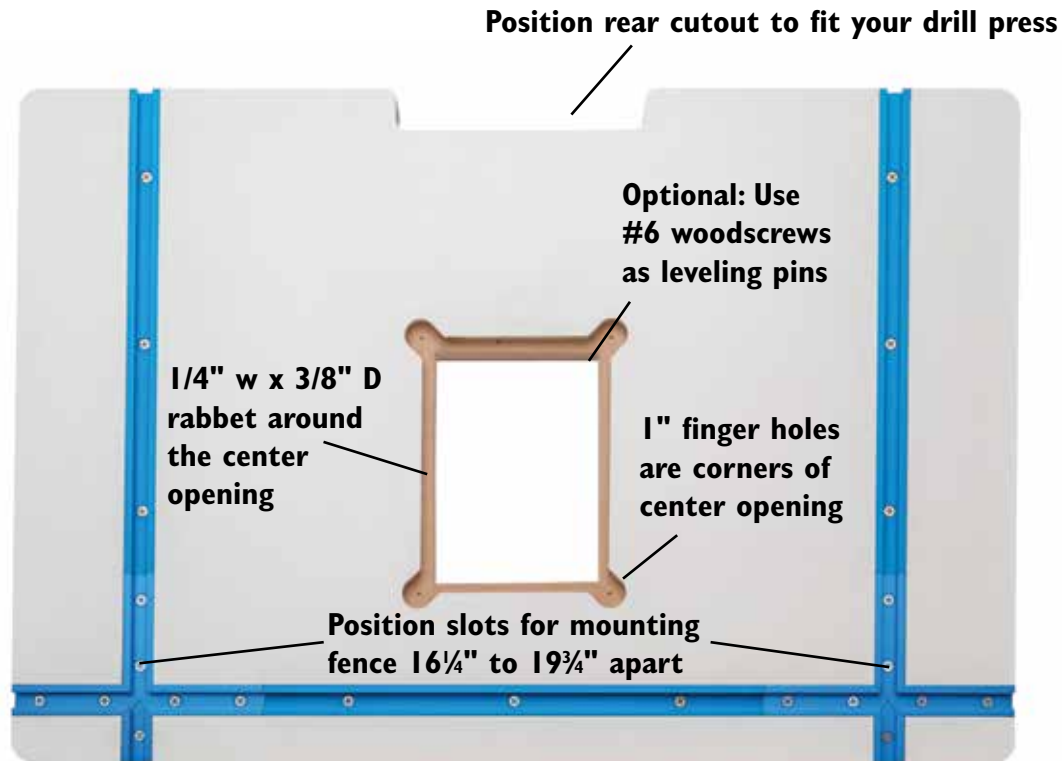

Making a Drill Press Table

This is a general plan. Customize the table dimensions and the size and position of the relief cutout at the back of the table to fit your drill press or work patterns.

1. Determine how long and wide you want the table to be. Cut your material to size.
Note: For stability, table material should be at least 1½" thick (or a lamination of equivalent thickness).
2. Determine where and how big the rear cutout for your drill press column needs to be. Mark your stock and make the cut with a jigsaw or band saw.
3. On the table's underside, use the **Center Opening Pattern** to locate the center opening; center it right to left and align the cross marks with the drill shaft.
4. Mark the outline and make the cut with a jigsaw.
5. Flip the table. With a bearing-guided rabbeting bit, cut a 1/4" W x 3/8" D rabbet around the opening.
6. Use a 1" diameter Forstner bit to drill finger holes at the four corners of the center opening.
7. Use a 3/4" router bit or a dado set in a table saw to cut 3/4" W x 3/8" D dados for the T-track. Cut the T-track to length, if necessary, with a hacksaw. File any rough edges. Install with #6 flathead screws.
8. Cut 4½" x 6" sacrificial inserts from 3/8" thick stock.

Check Rockler.com for updates. If you have further questions, please contact our Technical Support Department at 1-800-260-9663 or support@rockler.com

Mounting the Table to Your Drill Press



Method 1 - Drive woodscrews with FastCap Wood Washers (49034, sold separately) or fender washers through holes in your drill press' metal table to secure.



Method 2 - Install 5/16"-18 Screw-On Tee Nuts (68379, sold separately) on the underside of your shop-built table and use Rockler Hold-Down Clamps (35283, sold separately) to secure.